

# A new approach to Mu-antiMu conversion search

*NEWS colloquium, 27/May/'22*

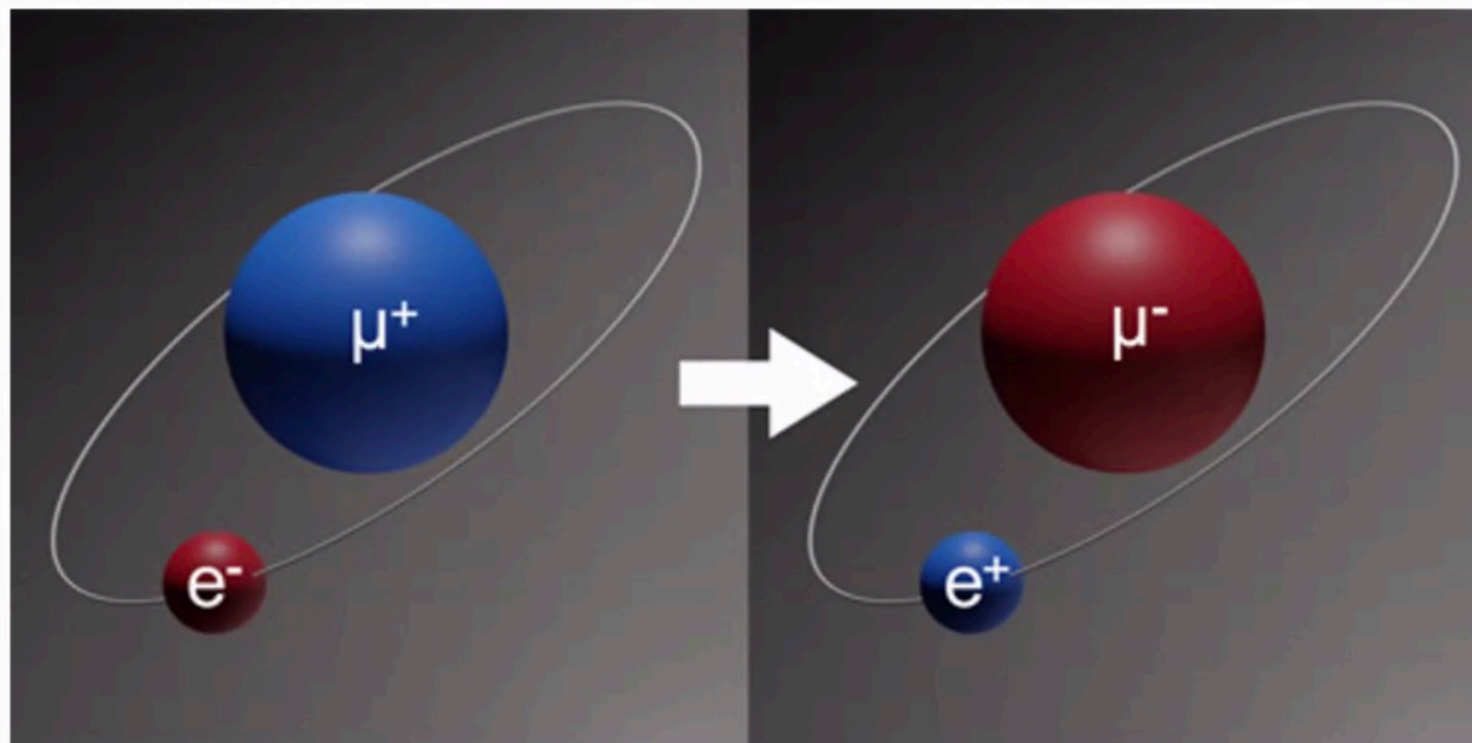

Naritoshi Kawamura  
Muon Sci. Sec., MLF div., J-PARC

# A little bit long introduction about fundamental physics using muon

Fundamental physics  $\approx$

elementary particle physics +

ultra-high-precision measurement for QED/EW/SM

In short, we, muon fundamental physicists, are aiming for

# Is why muon?

A new physics may not be affected only on the muon.  
Then, what is the reason why a muon is used?

## 【Technical reason】

- Easy to make
  - In the CM system, the threshold energy of muon generation is 140 MeV. (In the lab. system, 290 MeV.) **A large number of muon** can be generated by a middle energy accelerator.
- Easy to observe
  - A muon has a **moderate life time** ( $2.2\mu\text{s}$ ), and emits a **high-energy  $e^+/e^-$**  that is easy to observe.
  - A spin-polarized beam and spin-directional  $e^+/e^-$  emission reflect **the microscopic information of muons** themselves.

# Is why muon?

## 【Scientific reason】

- Muon has **no internal structure** (in the SM).
  - Relatively easy to improve the precision of theoretical calc.
- Affected by **only Electro<sup>o</sup>Weak** interaction
  - Strong interaction does not affect directly.  
(Only higher-order correction like vacuum polarization)
  - A muonium ( $\mu^+e^-$ ) is more of an ideal “hydrogen system” than a hydrogen.
- Mass scale of a new physics
  - **Sensitivity to a new physics** is expected to be scaled by the **square of mass**.
  - E.g., an electron is much easier to generate than a muon, but sensitivity is  $1/42,000 (=1/205.6^2)$ .

# Mass scale in a new physics

In Feynman diagram

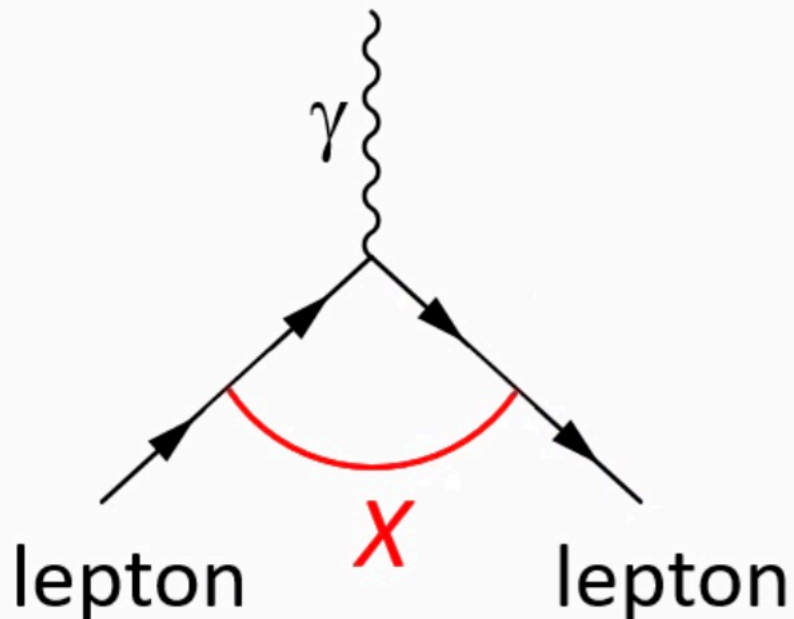

$$a_l(X) \sim C_X \left( \frac{m_l}{\Lambda_X} \right)^2$$

$C_X$  : Coupling strength

$\Lambda_X$  : Mass scale

$$\left( \frac{m_\mu}{m_e} \right)^2 \sim 43,000$$

$$\left( \frac{m_\tau}{m_\mu} \right)^2 \sim 280$$

A muon has much higher sensitivity than an electron

$\tau$  has higher sensitivity. But,  $\tau$  is much more difficult to generate.

# That's why muon!

- So far, SM was completed by the discovery of Higgs. But, SM cannot answer
  - Matter dominated universe
  - Dark matter, (dark energy?)
  - Layered structure of quarks and leptons
  - Neutrino oscillation
- It is obvious SM is a part of a greater system.
- Gather and investigate a **huge number of muons** to find "something strange" or "abnormal character", that can be an evidence of a new physics.
- Such studies are specialty in **high intensity frontier** facility like J-PARC MUSE.

# Muon Science toward BSM

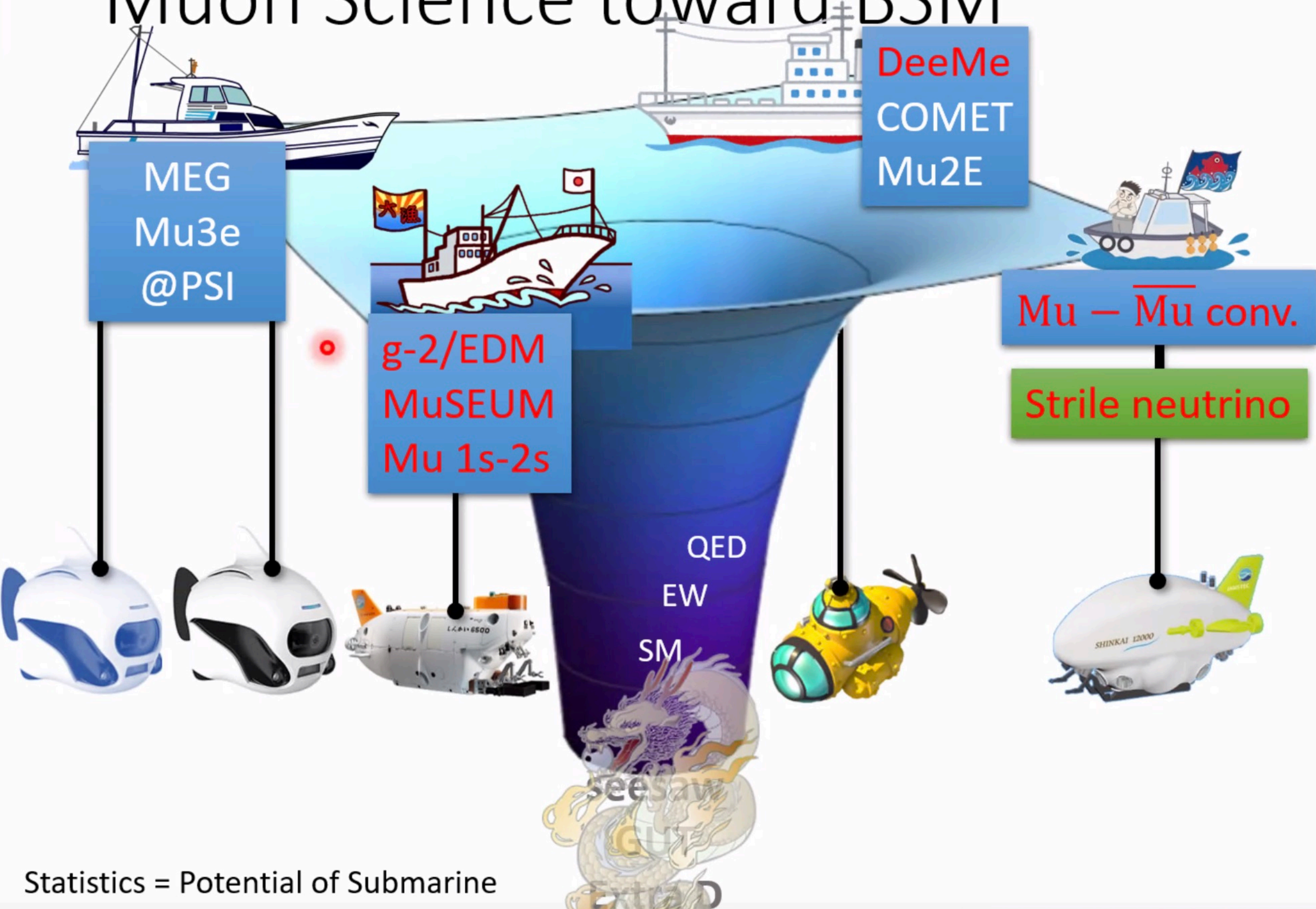

Statistics = Potential of Submarine

# High precision studies

Search abnormal character of muon

$\mu$   
 $g-2$

- hadronic contribution
- weak contribution
- New Physics

$$\mu_{\mu} = g_{\mu} \cdot \frac{e \cdot \hbar}{2 \cdot m_{\mu} \cdot c}$$

QED  
 $\mu_{\mu}, g_{\mu}$

QED  
 $m_{\mu}$

QED  
 $m_{\mu}$

$\mu^+e^-$   
 $\Delta v_{\text{HFS}, n=1}$

- $\mu_{\mu}$
- $\alpha$
- QED corrections
- weak contribution

$\mu^+e^-$   
 $\Delta v_{1S-2S}$

- $m_{\mu}$
- QED corrections



# Physics introduction

## ➤ Lepton Flavor Violation (LFV)

- $|\Delta L_i| = 1$

$$\mu^+ \rightarrow e^+ \gamma$$

$$\mu^+ \rightarrow e^+ e^+ e^-$$

$$\mu^+ - e^\pm \text{ conversion}$$

SUSY-GUT



- $|\Delta L_i| = 2$

$$\mu - \bar{\mu} \text{ conversion}$$

$$\mu^+ \rightarrow e^+ \nu_\mu \bar{\nu}_e$$

Exotic processes



(rare)<sup>2</sup>?

- Is the rate of “ $\Delta L = 2$ ” is square of “ $\Delta L = 1$ ”?  
Is there almost no hope to detect? 

(rare)<sup>2</sup>?

- Is the rate of “ $\Delta L = 2$ ” is square of “ $\Delta L = 1$ ”?  
Is there almost no hope to detect?



- No!  
They are expected in different models/mechanisms.

# History of Mu-antiMu conversion



**Predicted  
M-M  
Conversion  
1957-  
Named  
System  
“Muonium” ?**

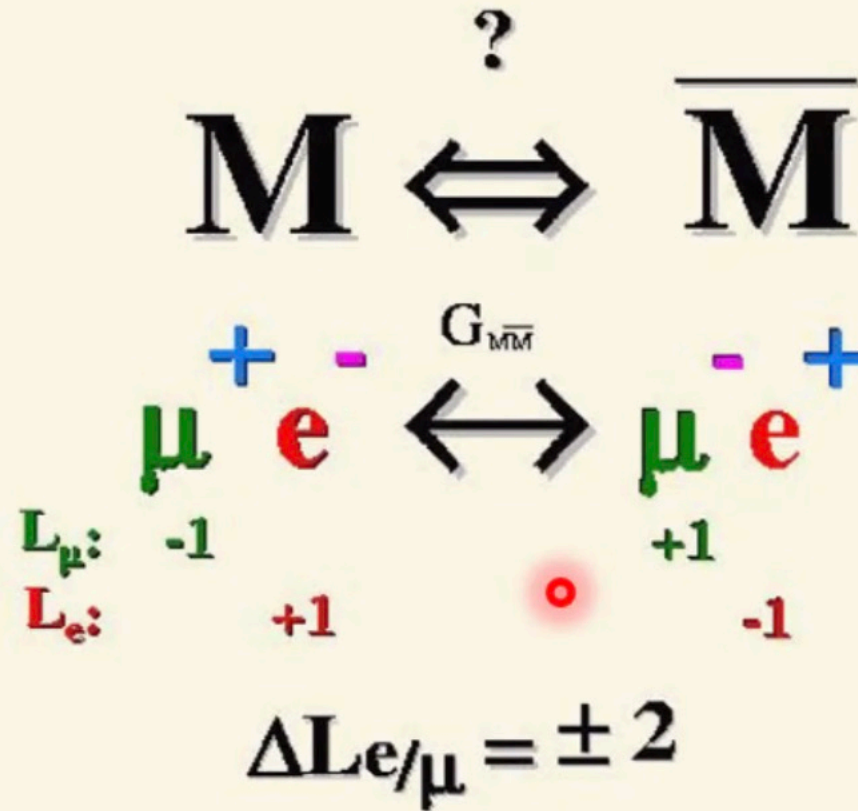

Flavour oscillations well established in quark sector :

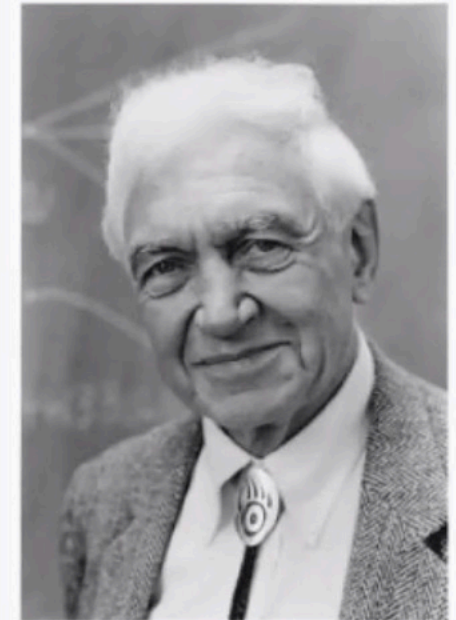

**Did first Search  
for Conversion**

*Amato et al.  
Phys.Rev.Lett. 21,  
1709 (1968)*

**Was significant  
Part of many  
follow on  
experiments**

# History of Muonium

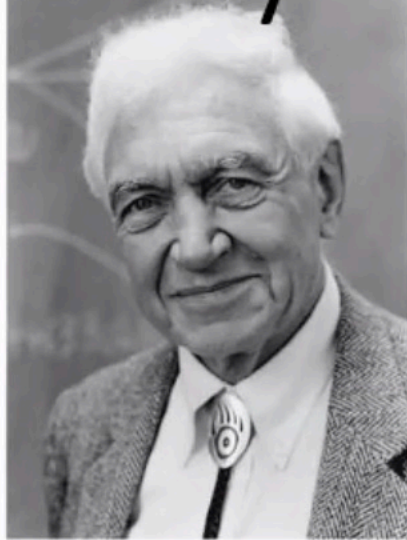

**There was stimulating competition**



## Discovery of Muonium 1960

208

---

VOLUME 5, NUMBER 2      PHYSICAL REVIEW LETTERS      JULY 15, 1960

---

FORMATION OF MUONIUM AND OBSERVATION OF ITS LARMOR PRECESSION\*

V. W. Hughes, D. W. McColm, and K. Ziock  
Gibbs Laboratory, Yale University, New Haven, Connecticut

and

R. Prepost  
Nevis Laboratory, Columbia University, New York, New York  
(Received June 17, 1960)

## Hyperfine Structure addressed as an Important Quantity

211

---

VOLUME 8, NUMBER 3      PHYSICAL REVIEW LETTERS      FEBRUARY 1, 1962

---

HYPERFINE STRUCTURE OF MUONIUM\*

K. Ziock, V. W. Hughes, R. Prepost, J. Bailey, and W. Cleland  
Yale University, New Haven, Connecticut  
(Received January 5, 1962)

1956      We invented  $\mu^+ e^-$ , misnamed it *muonium*

1957-1958      We failed to produce it !

1960      Yale/Nevis discovered it...

1964      They got  $\Delta v$  to 27 ppm (but...)

1969-1973      We had a couple of ideas, got  $\Delta v$  to 0.5 ppm

1977-1982      Yale/Heidelberg/LAMPF threw us into the dustbin of history ( $\Delta v$  to 0.04 ppm)

*SIC TRANSIT GLORIA MUNDI!*

# New physics to Mu-antiMu conv.

13/27

## Classification of new particles & interactions to generate Mu-to- $\bar{\mu}$ transition

### 1. $\Delta L_e = \Delta L_\mu = 0$

- mass term of SM singlet which violates lepton number
- loop
- e.g. Majorana  $\nu$  mass

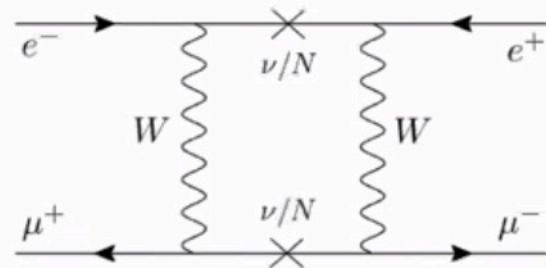

### 2. $(\Delta L_e, \Delta L_\mu) = (\pm 2, 0), (0, \pm 2)$

- doubly-charged mediator
- tree
- LNV is not needed.
- If mediator couples to  $W^+W^+$ ,  $0\nu 2\beta$  is induced.

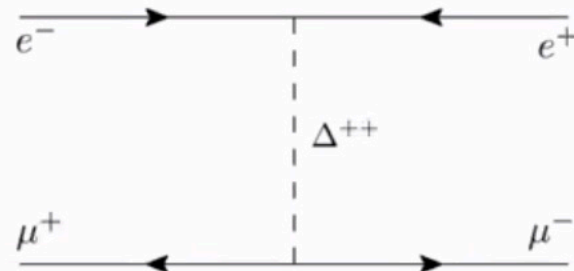

14/27

### 3. $\Delta L_e = -\Delta L_\mu = \pm 1$

- neutral mediator
- $\tau \rightarrow e$
- LNV is not needed.

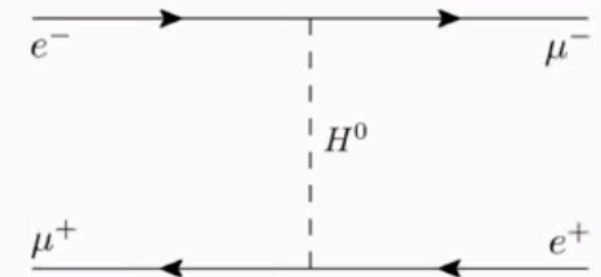

### 4. $(\Delta L_e, \Delta L_\mu) = (\pm 1, 0), (0, \pm 1)$

- loop
- model-independently, strongly constrained by  $\mu \rightarrow e\gamma$  or  $\mu \rightarrow 3e$

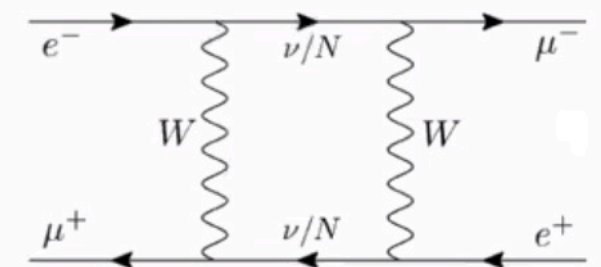

# Preceding study at PSI

## ➤ Setup

Surface muon (26 MeV/c)  
 $I_{\mu^+} = 8 \times 10^6 \mu^+ / s$   
 Beam time: 1730 hours  
 A  $\mu$  formed in  $\text{SiO}_2$  is evaporated to the vacuum  
 $N_{\text{Mu}} = 5.6 \times 10^{10}$

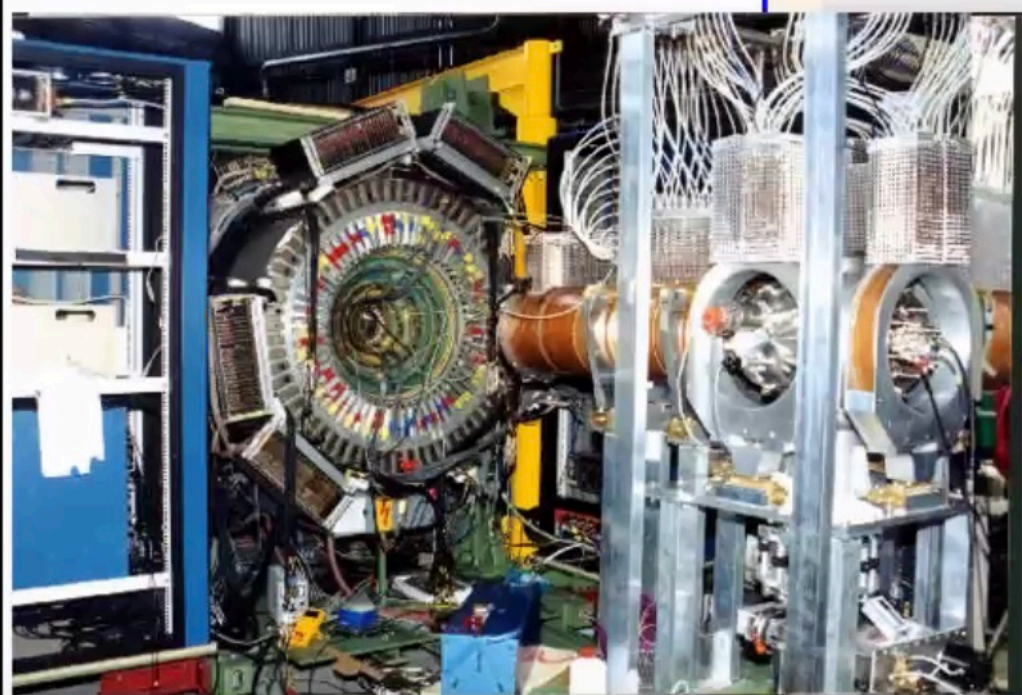
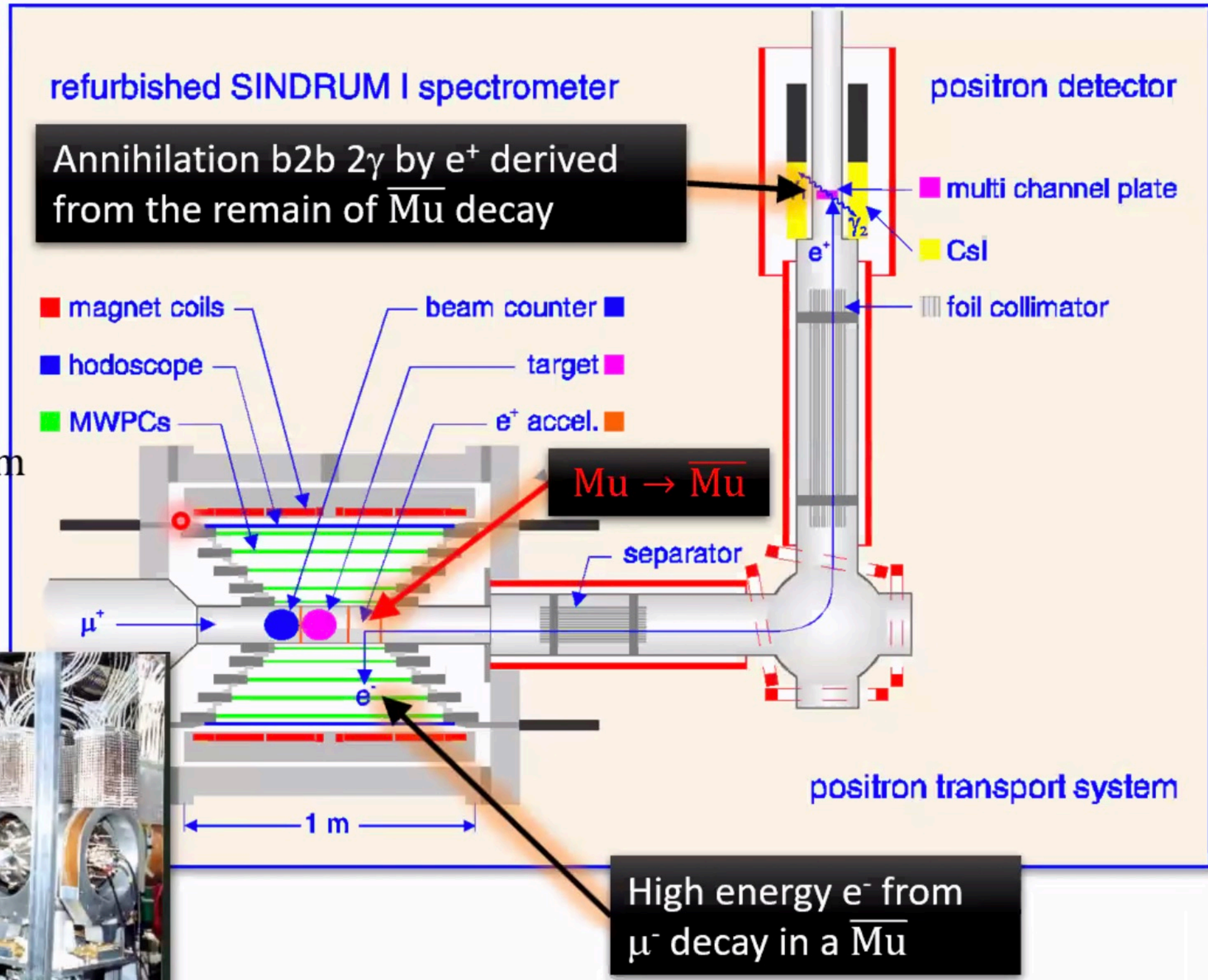

# Preceding study at PSI

## ➤ Result (1730h, $5.6 \times 10^{10}$ Mu)

$$P_{\text{Mu}\overline{\text{Mu}}} \leq 8.3 \times 10^{-11} \text{ (90\% C.L.)}$$

$$N_{\text{BG}} = 1.7$$

- Accidental coin. of  $e^-$  from Bhabha scattering of  $e^+$  and scattered  $e^+$
- $\mu^+ \rightarrow e^+e^+e^-\nu_e\bar{\nu}_\mu$  ( $BR = 3.4 \times 10^{-5}$ )

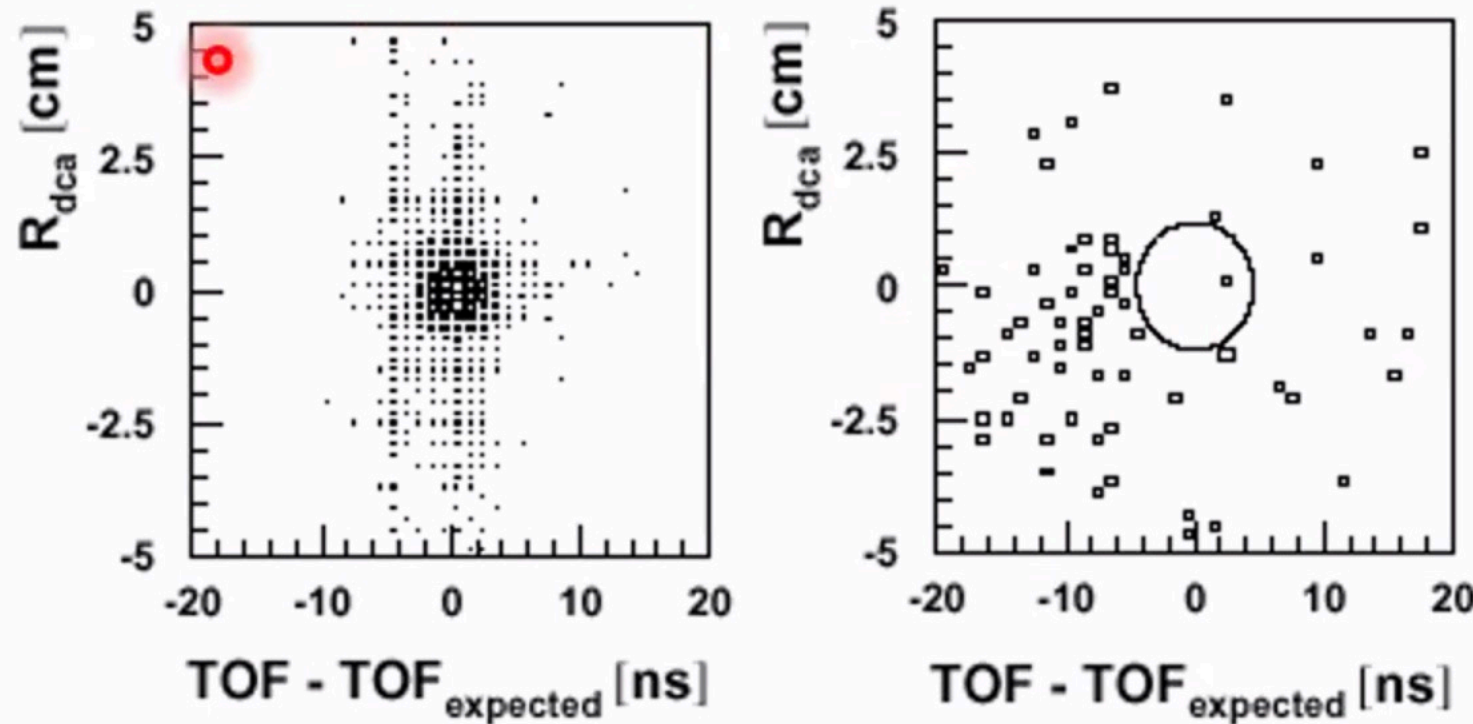

The result was limited by the intrinsic BG, and there is few hope for further improvement by increasing the statistical accuracy.

### New Bounds from a Search for Muonium to Antimuonium Conversion

L. Willmann<sup>1</sup>, P. V. Schmidt,<sup>1</sup> H. P. Wirtz,<sup>2</sup> R. Abela,<sup>3</sup> V. Baranov,<sup>4</sup> J. Bagaturia,<sup>5</sup> W. Bertl,<sup>3</sup> R. Engfer,<sup>2</sup> A. Großmann,<sup>1</sup> V. W. Hughes,<sup>6</sup> K. Jungmann,<sup>1</sup> V. Karpuchin,<sup>4</sup> I. Kisel,<sup>4</sup> A. Korenchenko,<sup>4</sup> S. Korenchenko,<sup>4</sup> N. Kravchuk,<sup>1</sup> N. Kuchinsky,<sup>1</sup> A. Leuschner,<sup>2</sup> V. Meyer,<sup>1</sup> J. Merkel,<sup>1</sup> A. Moiseenko,<sup>3</sup> D. Mzavia,<sup>5</sup> G. zu Putlitz,<sup>1</sup> W. Reichart,<sup>2</sup> I. Reinhard,<sup>1</sup> D. Renker,<sup>3</sup> T. Sakhelashvili,<sup>5</sup> K. Träger,<sup>1</sup> and H. K. Walter<sup>3</sup>

<sup>1</sup>Physikalisches Institut, Universität Heidelberg, D-69120 Heidelberg, Germany  
<sup>2</sup>Physik Institut, Universität Zürich, CH-8057 Zürich, Switzerland  
<sup>3</sup>Paul Scherrer Institut, CH-5232 Villigen PSI, Switzerland  
<sup>4</sup>Joint Institute of Nuclear Research, RU-141980 Dubna, Russia  
<sup>5</sup>Tbilisi State University, GUS-380086 Tbilisi, Georgia  
<sup>6</sup>Physics Department, Yale University, New Haven, Connecticut 06520-8121

(Received 13 July 1998)

A new upper limit for the probability of spontaneous muonium to antimuonium conversion was established at  $P_{\text{Mu}\overline{\text{Mu}}} \leq 8.3 \times 10^{-11}$  (90% C.L.) in 0.1 T magnetic field, which implies consequences for speculative extensions to the standard model. Coupling parameters in  $R$ -parity-violating supersymmetry and the mass of a flavor diagonal bileptonic gauge boson can be significantly restricted. A  $Z_\mu$  model with radiative mass generation through heavy lepton seed and the minimal version of 331 models are disfavored. [S0031-9007(98)08068-5]

PACS numbers: 11.30.Fs, 11.30.Hv, 13.10.-q, 36.10.Dr

At present, all confirmed experimental experience is in agreement with conserved lepton numbers. Several solely empirical laws appear to hold simultaneously, including multiplicative and additive schemes [1]. No associated symmetry has yet been identified, thus leaving lepton numbers in a unique status in physics, since flavor mixing in the quark sector is well established and described by the Cabibbo-Kobayashi-Maskawa matrix. The standard model in particle physics assumes additive lepton number conservation, and any observed violation would be a clear indication of new physics. In many speculative theories, which extend the standard model in order to explain some of its features such as parity violation in the weak interactions or  $CP$  violation, lepton flavors are not conserved. These theories have motivated a variety of dedicated sensitive searches for rare decay modes of muons and kaons [2] and for neutrino oscillations.

Of particular interest is the muonium atom ( $M = \mu^+e^-$ ) which consists of two leptons from different generations. As the electromagnetic part of the binding is well described by electroweak standard theory it renders the possibility of a search for additional, yet unrevealed electron-muon interactions. A spontaneous conversion of muonium into antimuonium ( $\overline{M} = \mu^-e^+$ ) would violate the additive lepton family number conservation by two units; however, it is allowed by a multiplicative law. This process could play a decisive role in many speculative models (Fig. 1) [3-9].

The measurements reported here were performed with the muonium-antimuonium conversion spectrometer (MACS) whose design is based on the observation of  $M$  atoms *in vacuo*. In matter the possible conversion is strongly suppressed mainly due to the loss of symmetry between  $M$  and  $\overline{M}$  due to the possibility of  $\mu^-$  transfer

in collisions involving  $\overline{M}$  [10,11]. The required signature of a conversion process is the coincident identification of both the electron and positron released in the decay of the antiatom [12,13]. An energetic electron ( $e^-$ ) arises from the decay  $\mu^- \rightarrow e^- + \nu_\mu - \bar{\nu}_e$  with a characteristic Michel energy distribution extending to 53 MeV [14], and a positron ( $e^+$ ) appears with an average kinetic energy of 13.5 eV corresponding to its momentum distribution in the atomic  $1s$  state of  $\overline{M}$  [15].

The setup has a large acceptance for these charged final state particles (Fig. 2). Its symmetry for detecting  $M$  and  $\overline{M}$  decays through reversing all electric and magnetic fields is exploited in regular measurements of the  $M$  atom production yield which is required for normalization and, in addition, for monitoring detector performance. As a particular advantage, systematic uncertainties arising from corrections for efficiencies and acceptances of various detector components cancel out.

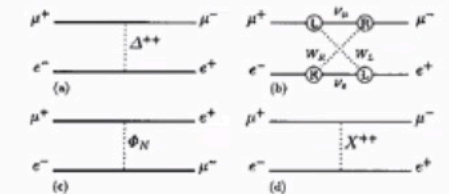

FIG. 1. Muonium-antimuonium conversion in theories beyond the standard model. The interaction could be mediated, e.g., by (a) doubly charged Higgs boson  $\Delta^{++}$  [3,4], (b) heavy Majorana neutrinos [3], (c) a neutral scalar  $\Phi_N$  [5], e.g., a supersymmetric  $\tau$ -neutrino  $\tilde{\nu}_\tau$  [6,7], or (d) a bileptonic flavor diagonal gauge boson  $X^{++}$  [8,9].



# New idea

- Why don't you detect antiMu more directly?
- Assuming CPT symmetry, antiMu is the same as Mu in any internal transitions, like 1s-2p, 1s-2s, hyperfine *etc* under zero-field.
- The only way is breaking antiMu.
  - Waiting for breaking antiMu naturally → PSI
    - Breaking antiMu =  $\mu^-$  free-decay to  $e^-$   
→ high BG
  - Breaking antiMu artificially → present work
    - Breaking antiMu = ionization of antiMu to  $\mu^-$  and  $e^+$   
→ direct detection of  $\mu^-$  → low BG

# Meson factories in the world

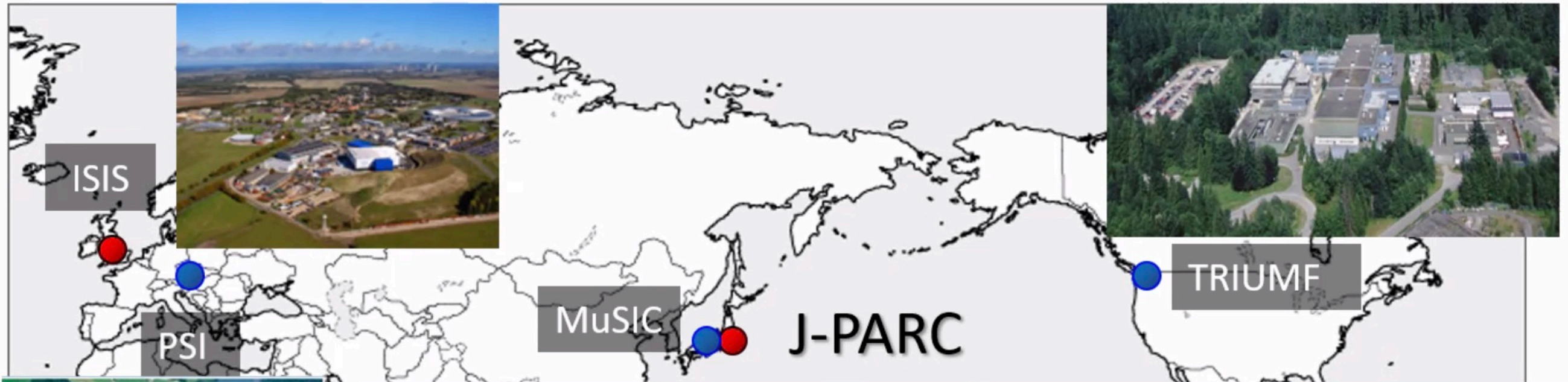

Nation	Switzerland	UK	Japan
Facility	PSI	RAL ISIS	J-PARC MUSE
Proton energy [GeV]	0.59	0.8	3.0
Proton intensity [MW]	1.3	0.16	1.0 (design value)
$\mu^+$ [/s] (surface)	$2 \times 10^8$	$6 \times 10^5$	$2 \times 10^8$
$\mu^-$ [/s]	$2 \times 10^7$	$7 \times 10^4$	$1 \times 10^7$
Beam structure	DC (CW)	Pulse (50Hz)	Pulse (25Hz)

# U line

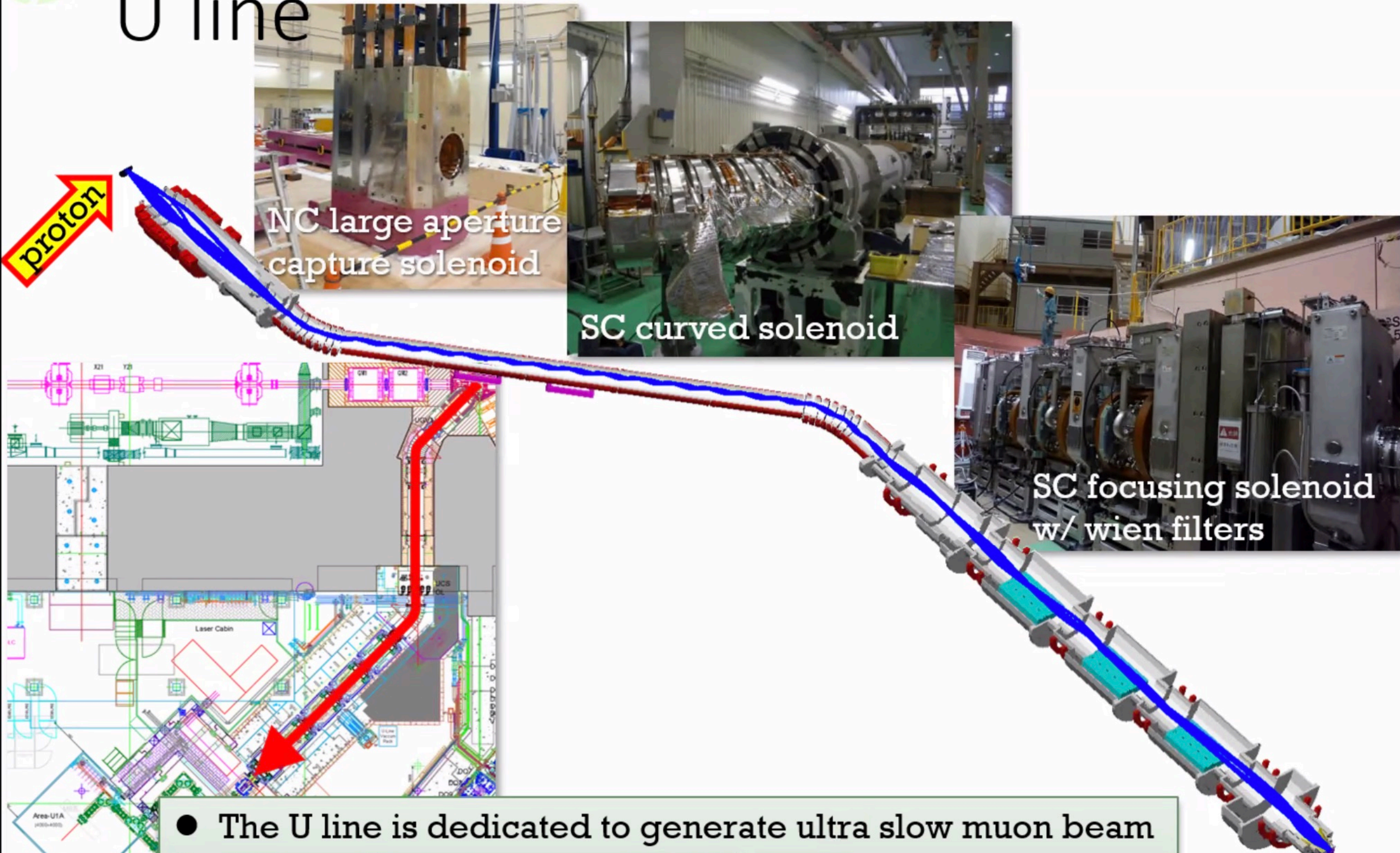

- The U line is dedicated to generate ultra slow muon beam
- All beamline magnets are axial focusing
- The world strongest pulsed muon:  $2 \times 10^8 \mu^+/\text{s}$ ,  $1 \times 10^7 \mu^-/\text{s}$

# U line (cont.)

## Laser resonant ionization

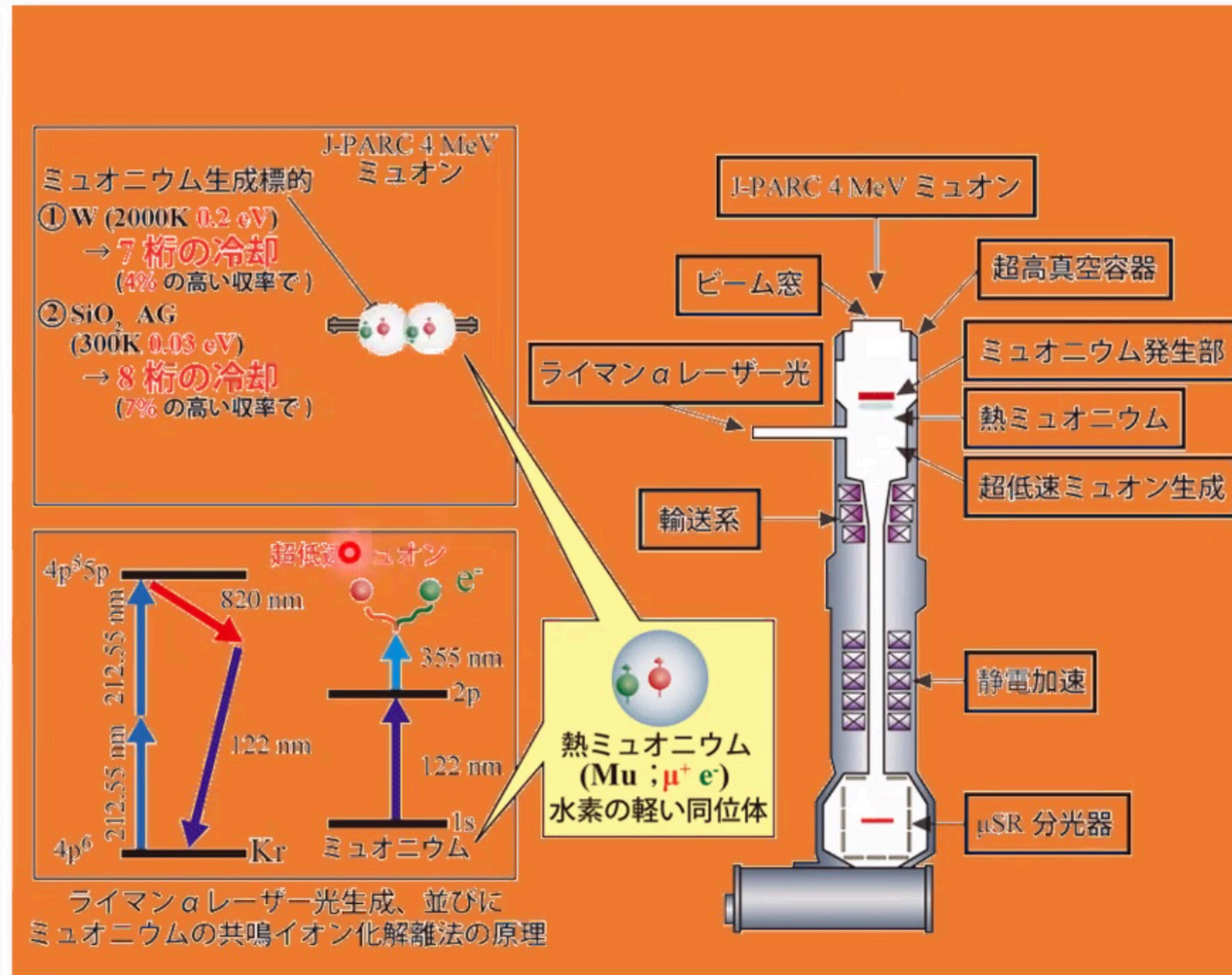

# Background study

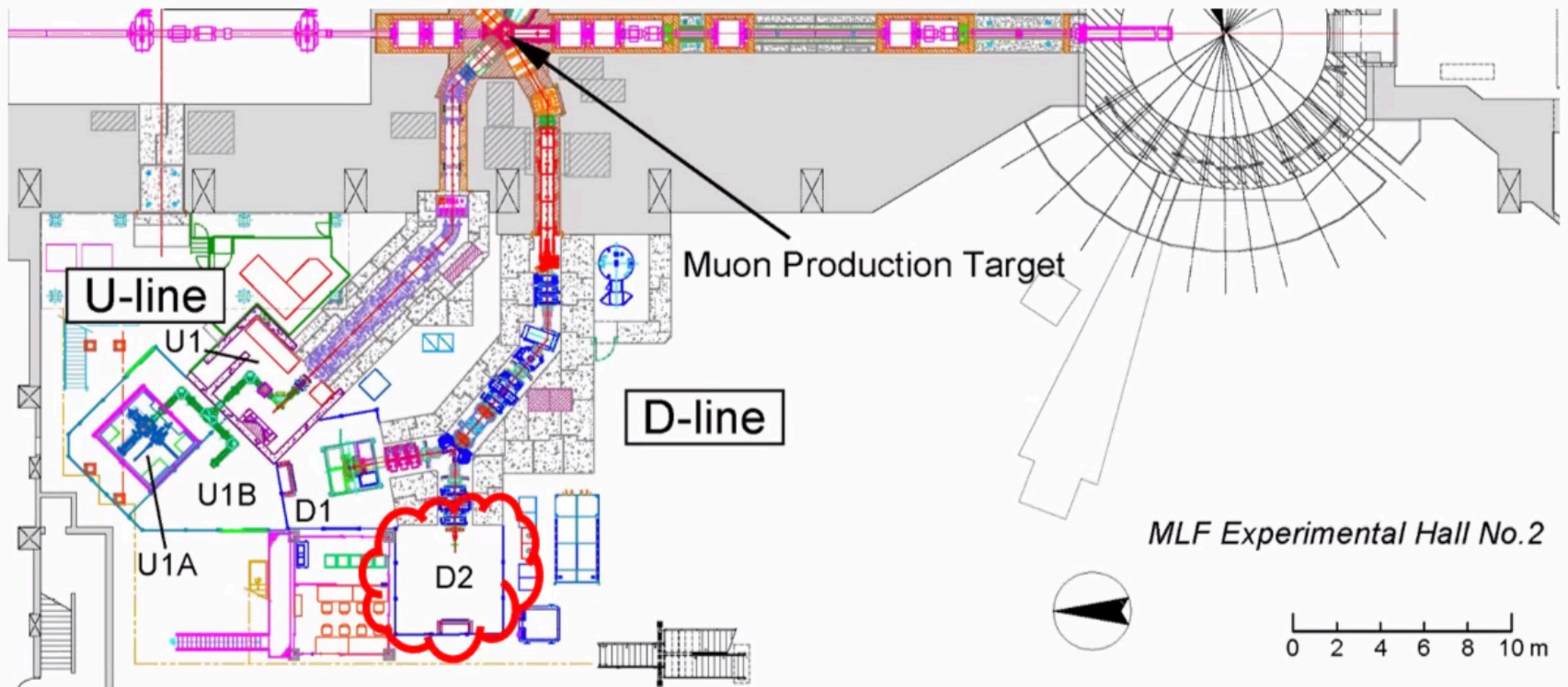

## U line

Surface muon (4MeV)  $2 \times 10^8$  /s @1MW

Ultra slow muon beam (eV ~ keV) ●

U1A: Surface and interface study  
for material science

U1B: micro beam  
by re-acceleration of USM

## D line

Surface muon  $1 \times 10^7$  /s

Decay muon ( $\mu^+/\mu^-$ : 50 keV ~ 50 MeV)

D1: permanent  $\mu$ SR spectrometer

D2: open area for versatile use

Feasibility check (BG measurement)  
was performed in D2 area in Dec/'16  
and Feb/'19.

# Background study cont.

Apparatus of  $\text{Mu}^-$  study for  $g-2/\text{EDM}$  was applied.

BG level was checked **w/o laser**

Optics is tuned for  $\text{Mu}^-/\mu^-$

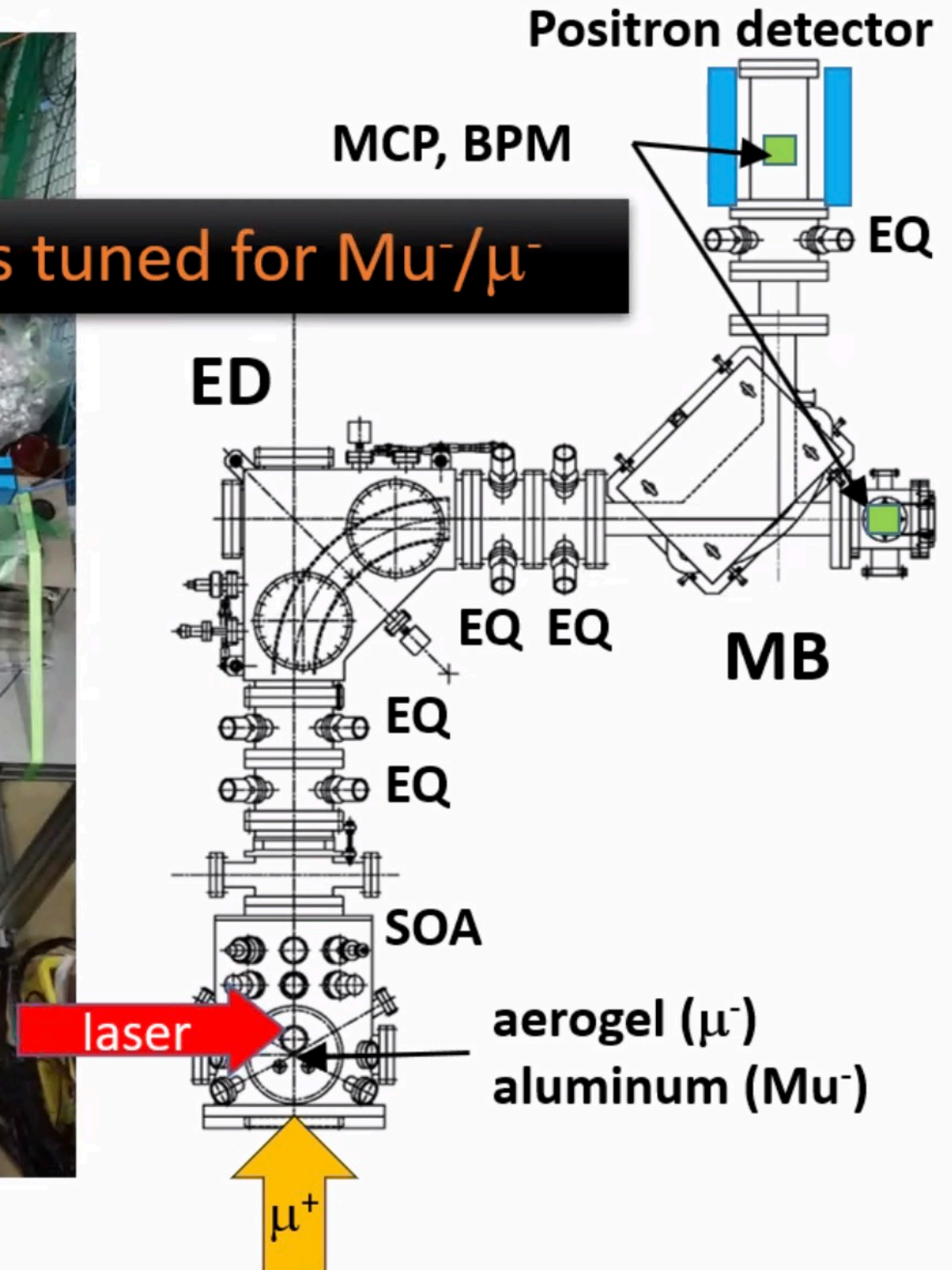
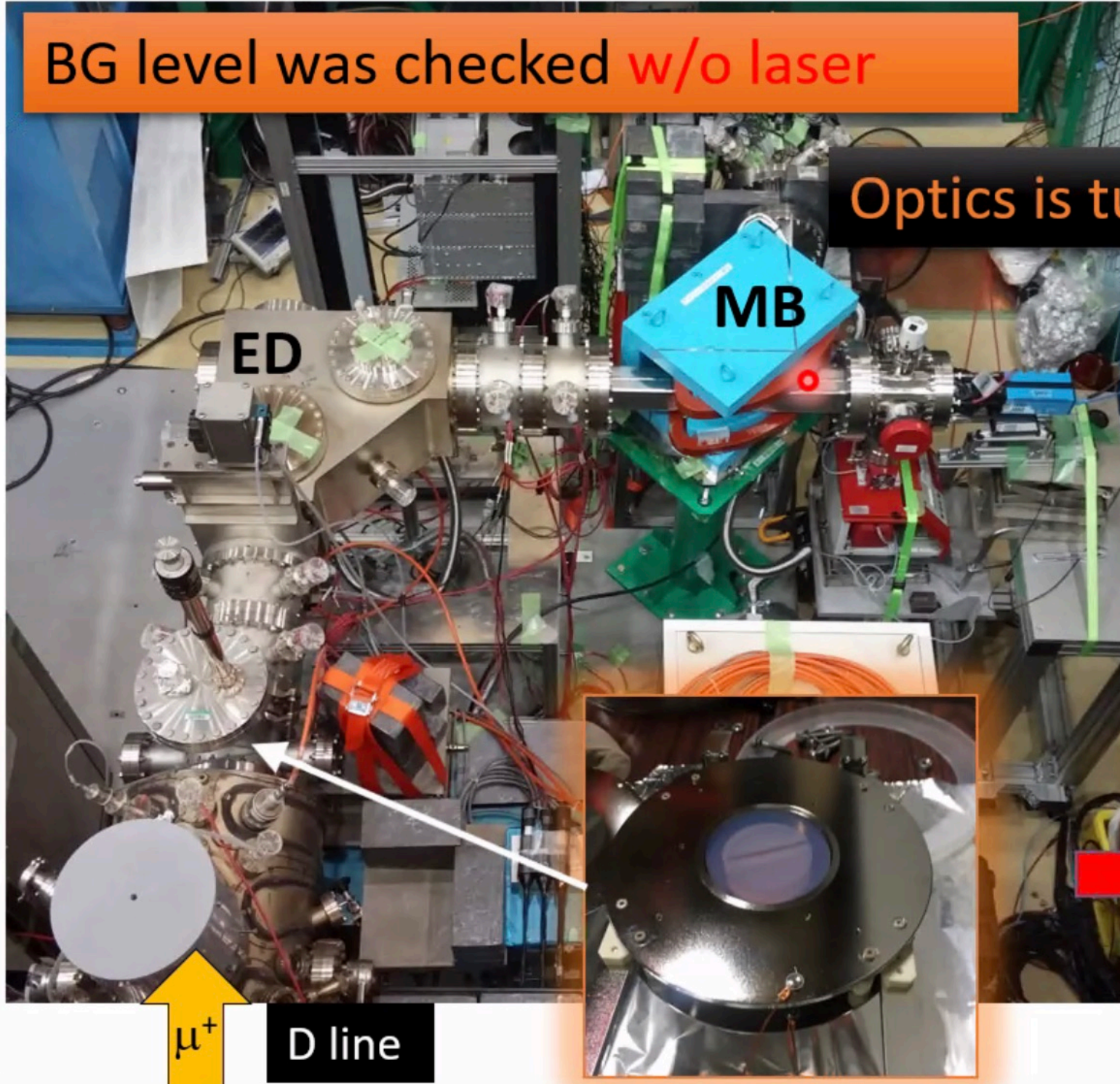

# Preliminary analysis

Time spectrum passing the ED

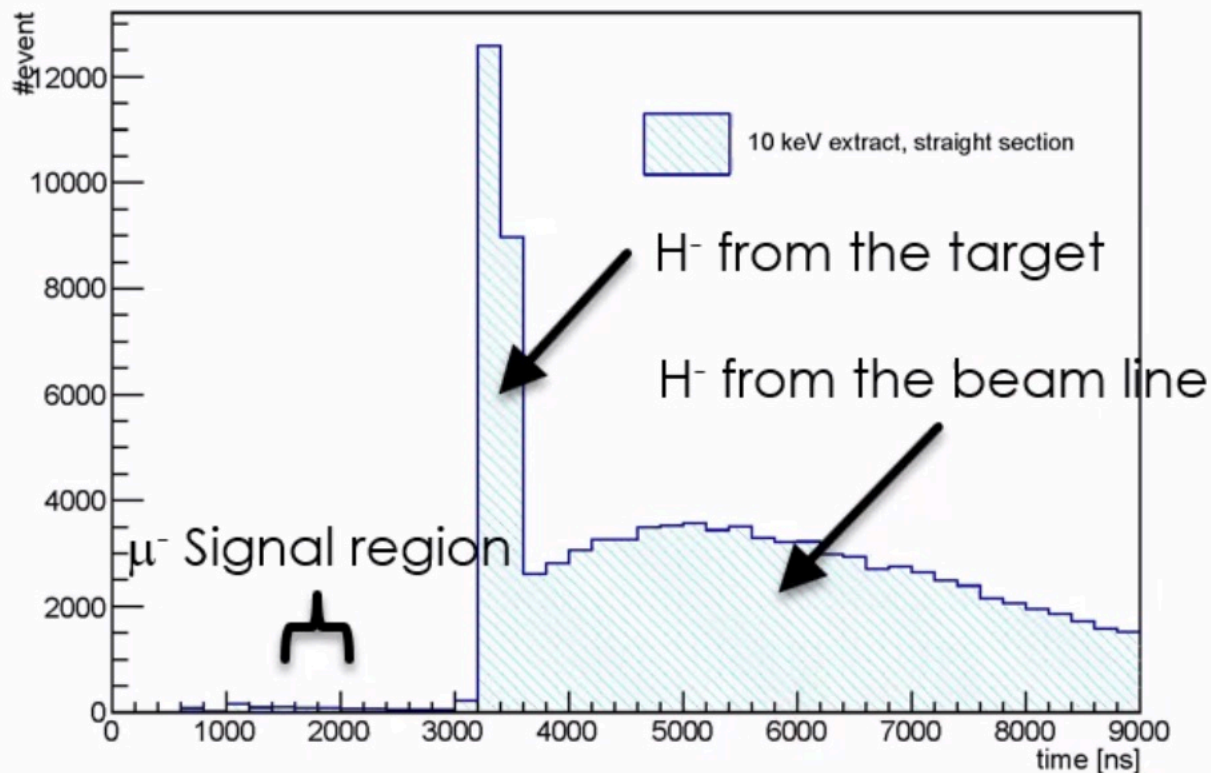

Time spectrum passing EB+MB

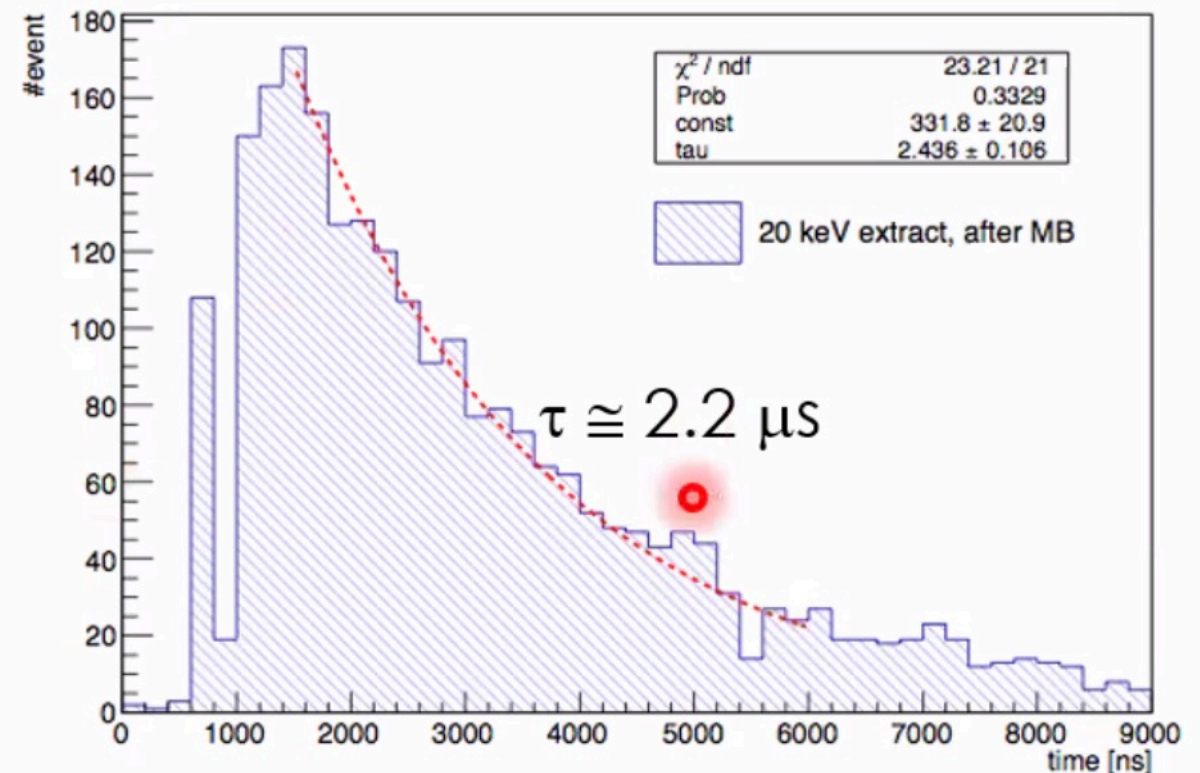

- Main BG is H<sup>-</sup>s, and they are reduced by below 1/10000 with the pair of ED and MB.
- A component with the muon life time remains.
- The origin of muon-life BG
  - Direct Michel e<sup>+</sup> from μ<sup>+</sup> stopping around the target
  - e<sup>-</sup> by Michel e<sup>+</sup> Bhabha scattering around/after ED
    - They reach at MCP directly / through the beamline components.

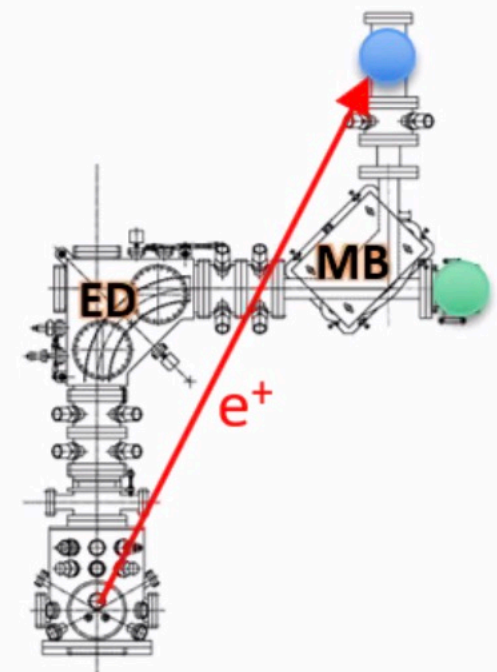

# Preliminary analysis (cont.)

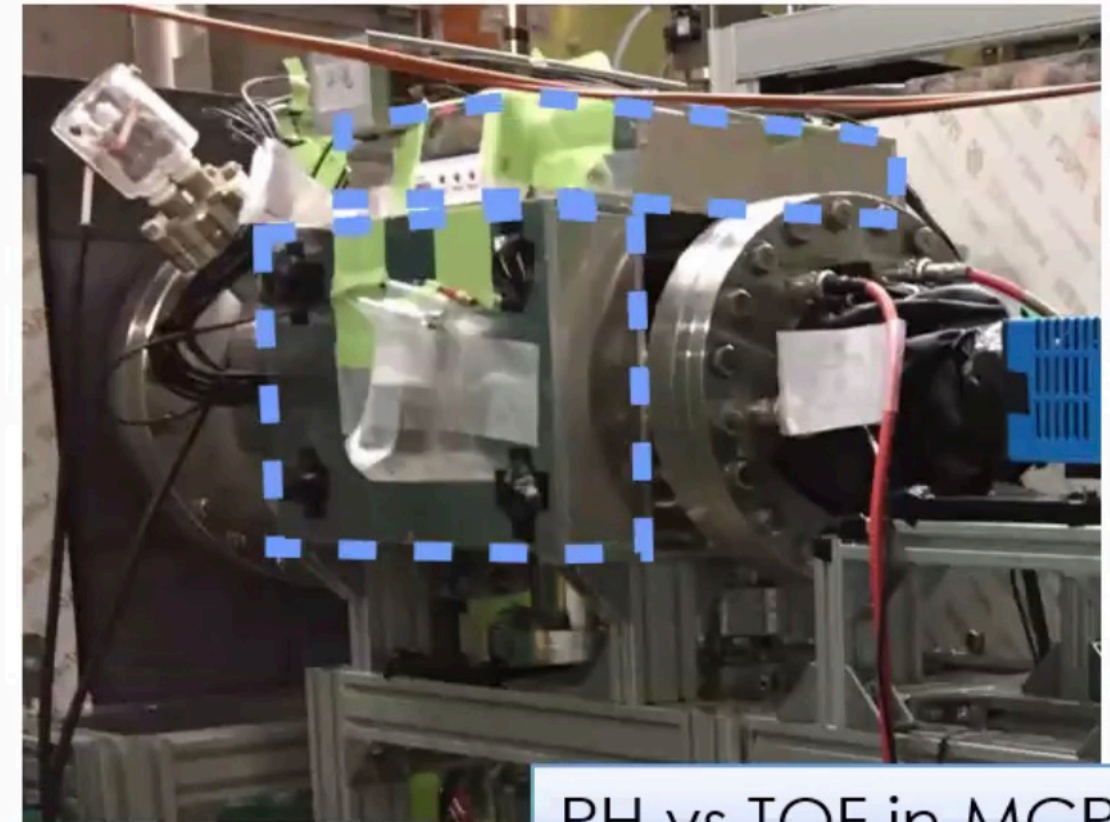
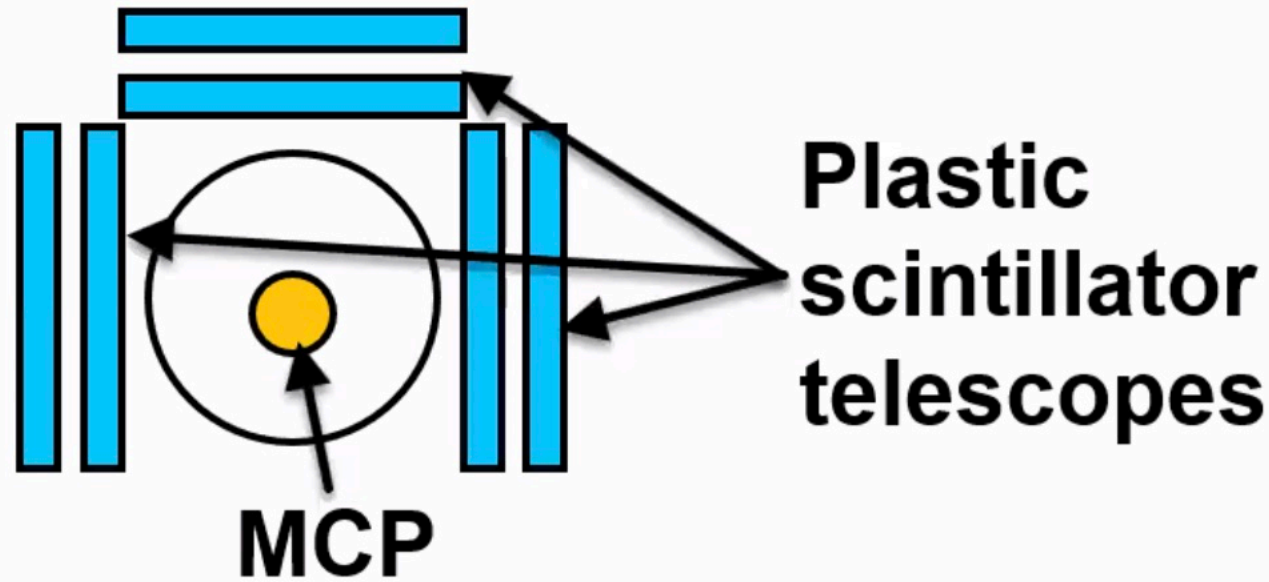

PH vs TOF in MCP

- Half-a-day run,  $\sim 10^{10}$   $\mu$  incident
- 4 events remain by applying
  - Coincident signal in surrounding PS telescopes
  - time window  $\mu^-$  arrival to MCP
  - Pulse height threshold higher than  $e^-/e^+$  events
- The origin of 4 events could be due to  $Mu^-$  from the metallic parts around the aerogel target.

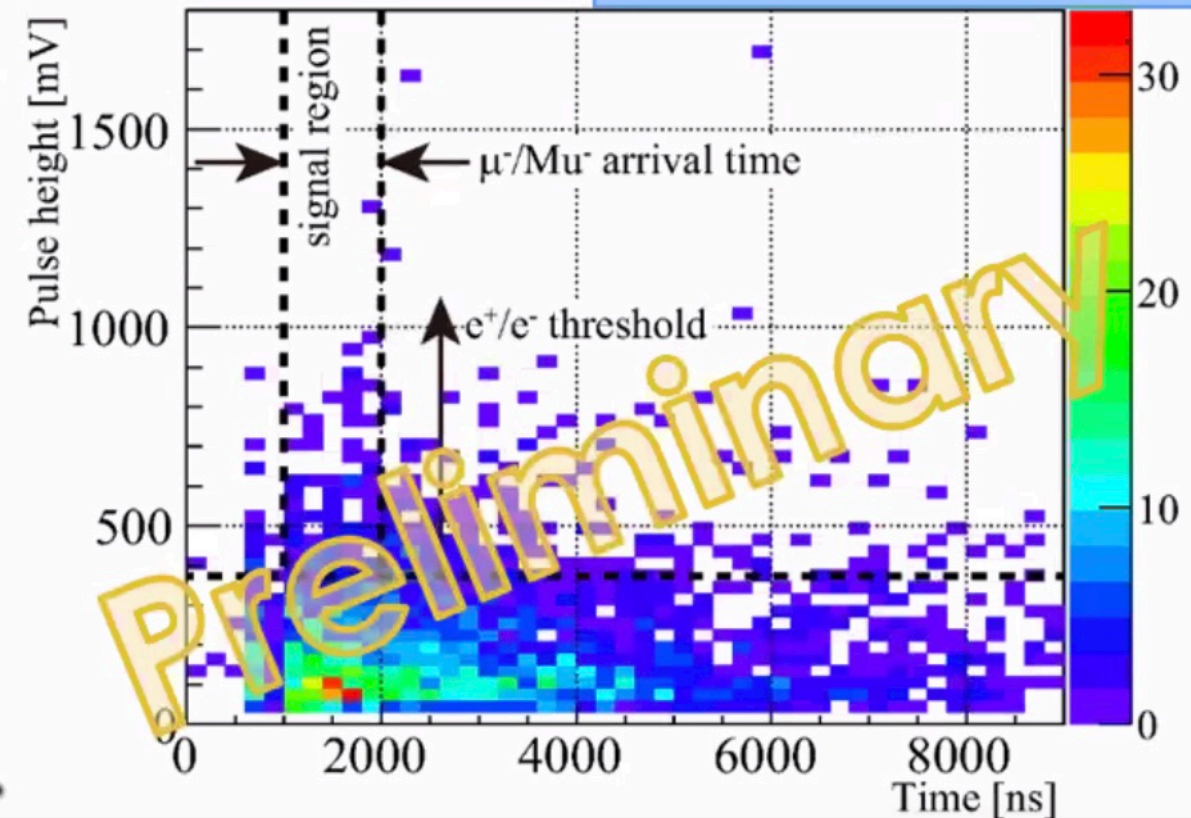



# Mu<sup>-</sup>

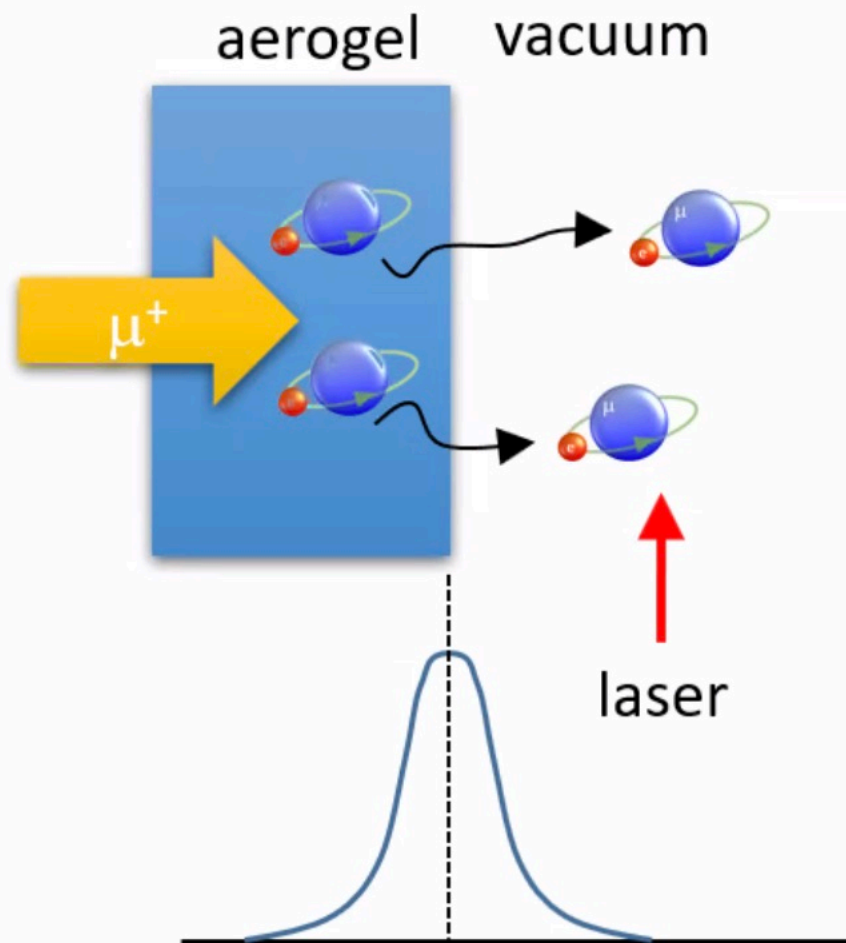

muon stopping distribution

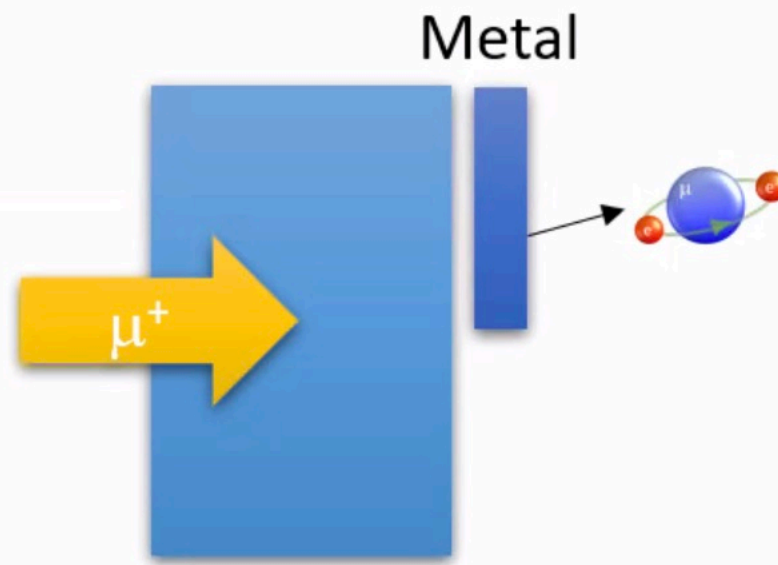

It is known that Mu<sup>-</sup> ( $\mu^+ e^- e^-$ ) is emitted from the metal surface, similar to H<sup>-</sup>.  
 Y. Kuang *et al*, PRA 39 (1989) 6109.

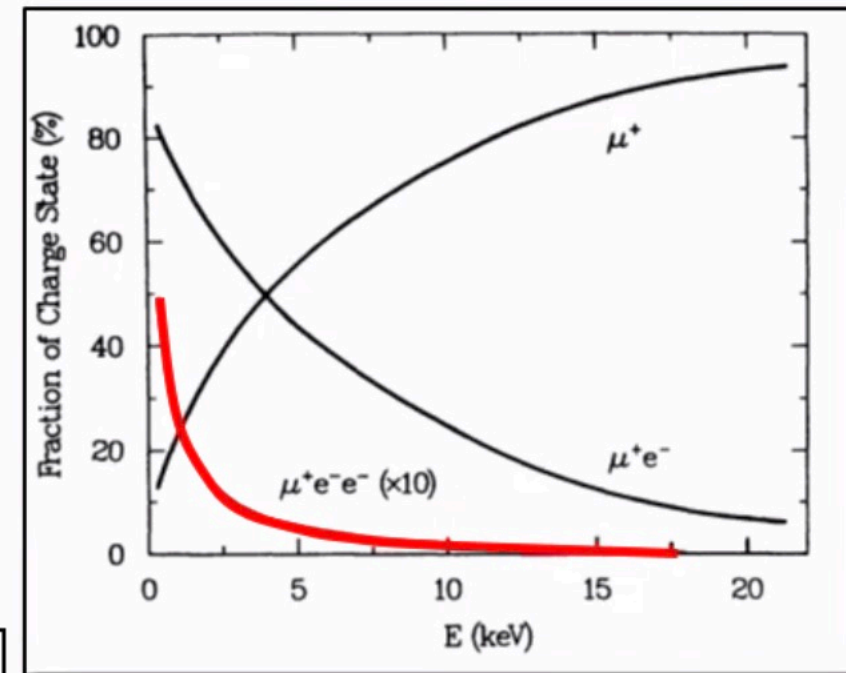

Mu is generated and diffused in the aerogel, and then evaporated from the surface. **Half stop condition** (the peak of the stopping distribution is at the rear surface) is the best to maximize the Mu yield in the vacuum region.

Mu<sup>-</sup> is hard to distinguish from μ<sup>-</sup> because the charge and the mass are almost the same. In addition, Mu<sup>-</sup> emits e<sup>+</sup> with the lifetime of 2.2 μs.

# $\mu^-$ detection

- If  $\mu^-$  is reached at MCP, how to detect.

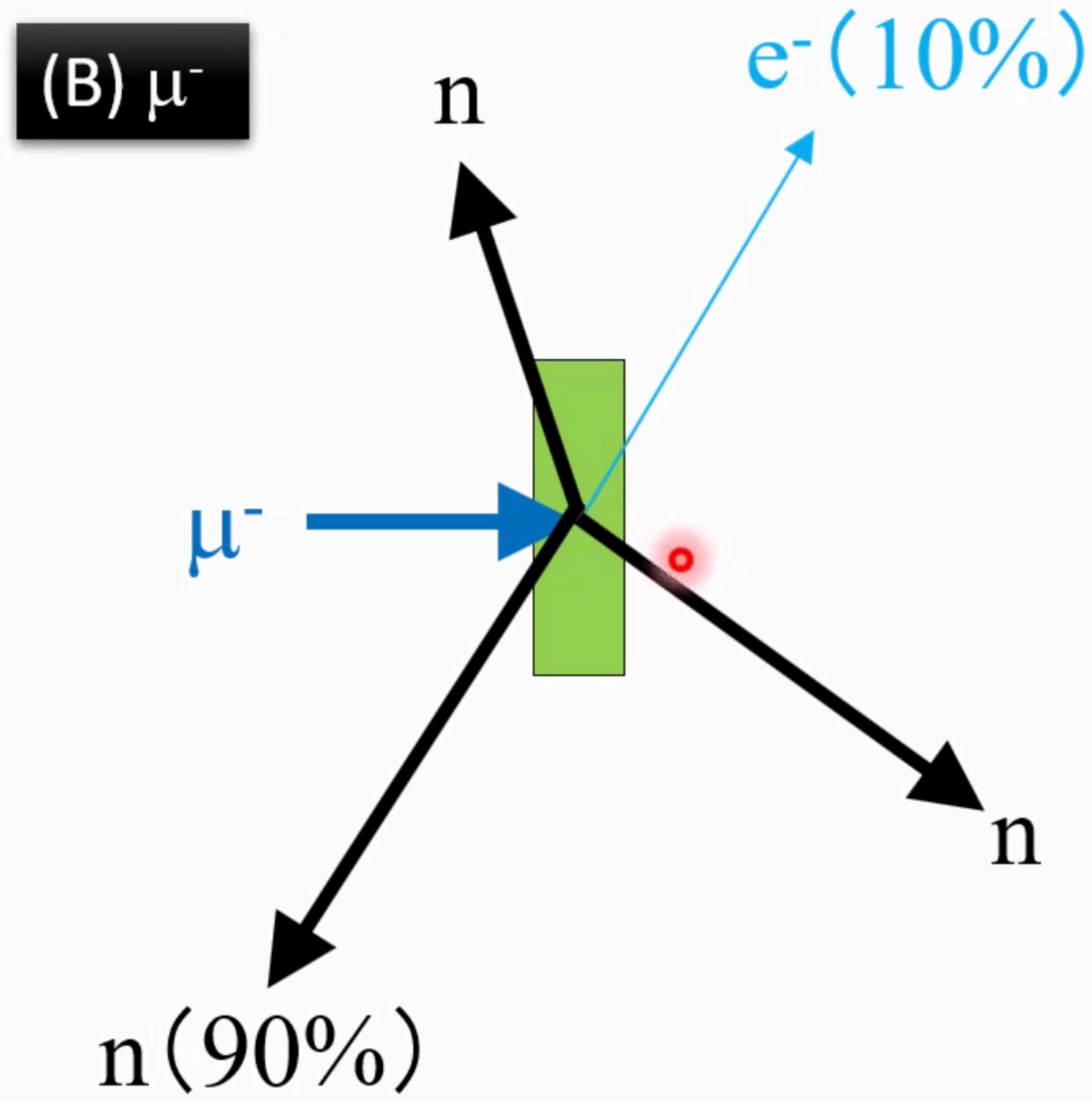
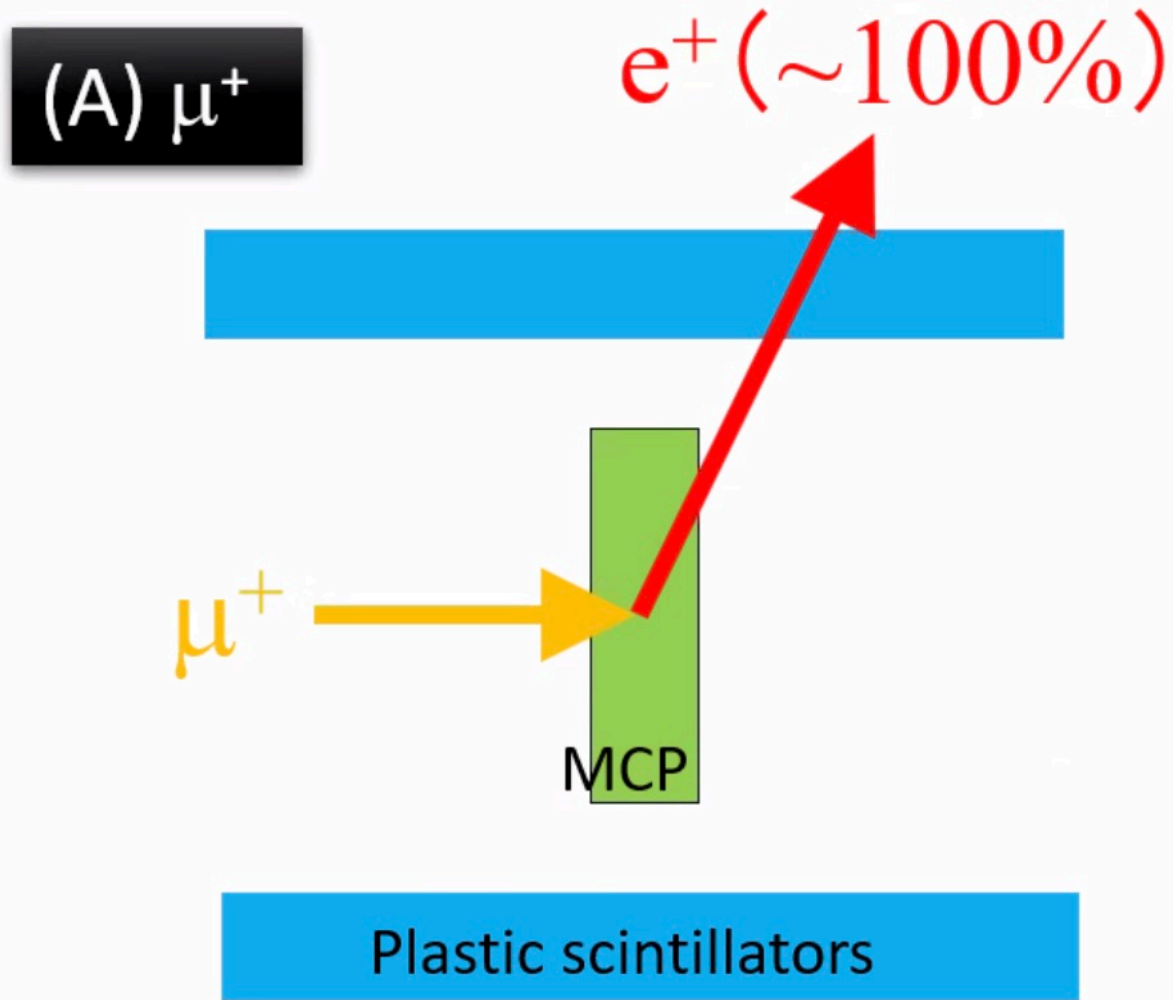

The cost of developing the detector and so on is granted in KAKENHI-B from this FY.

# $\mu^-$ detection

- If  $\mu^-$  is reached at MCP, how to detect.

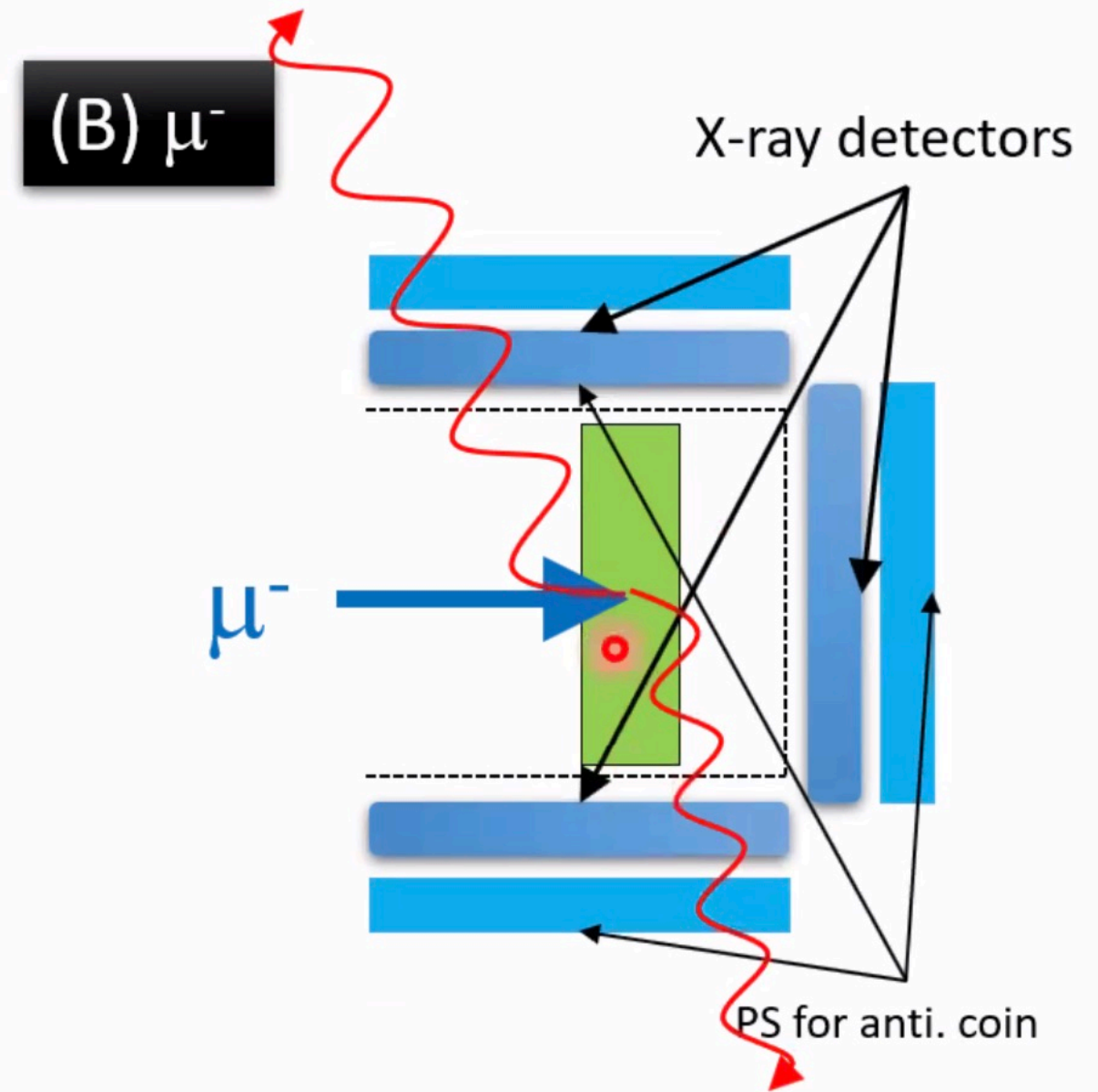
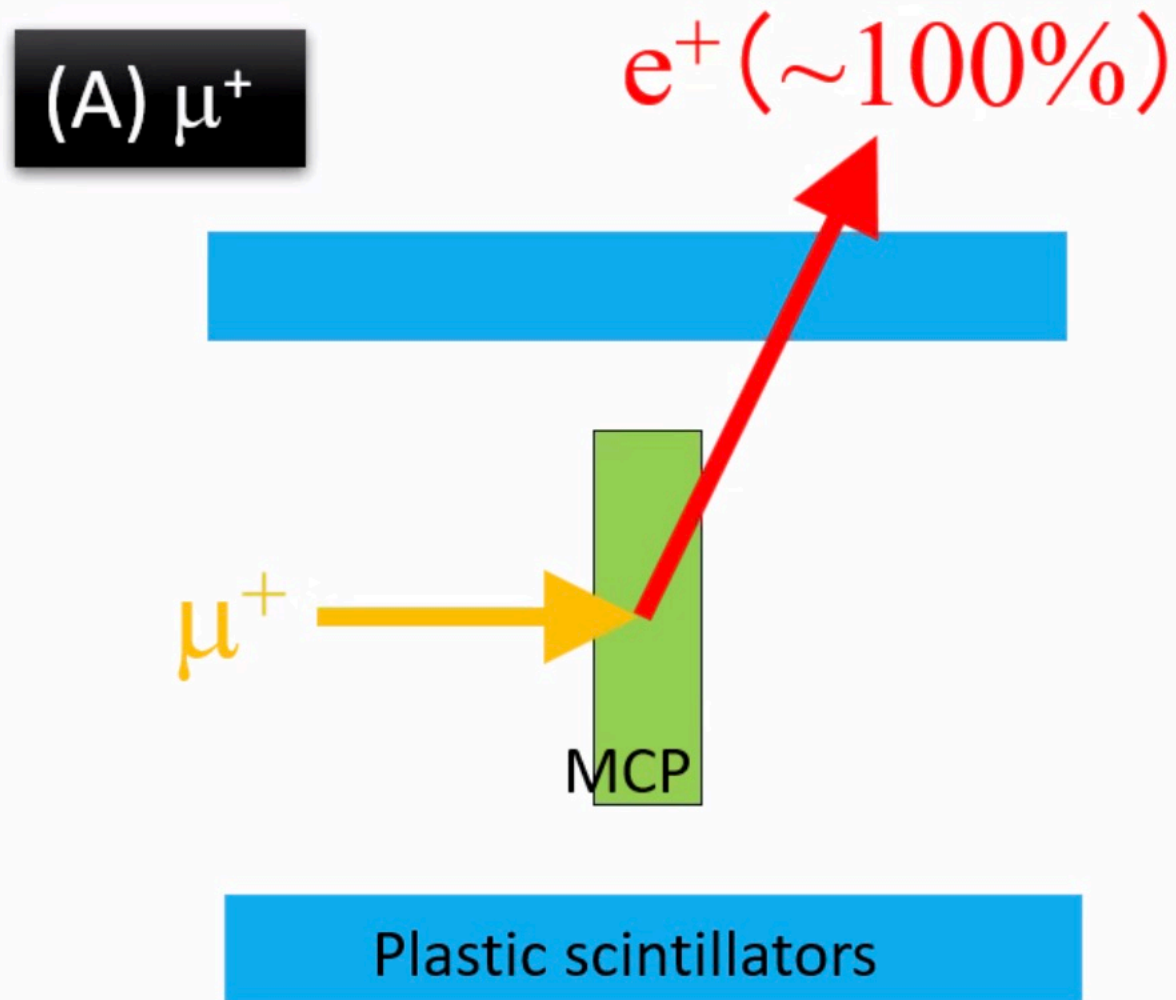

characteristic X-rays

The cost of developing the detector and so on is granted in KAKENHI-B from this FY.

# Details about Mu Production



## • Gas Stop

MuSEUM

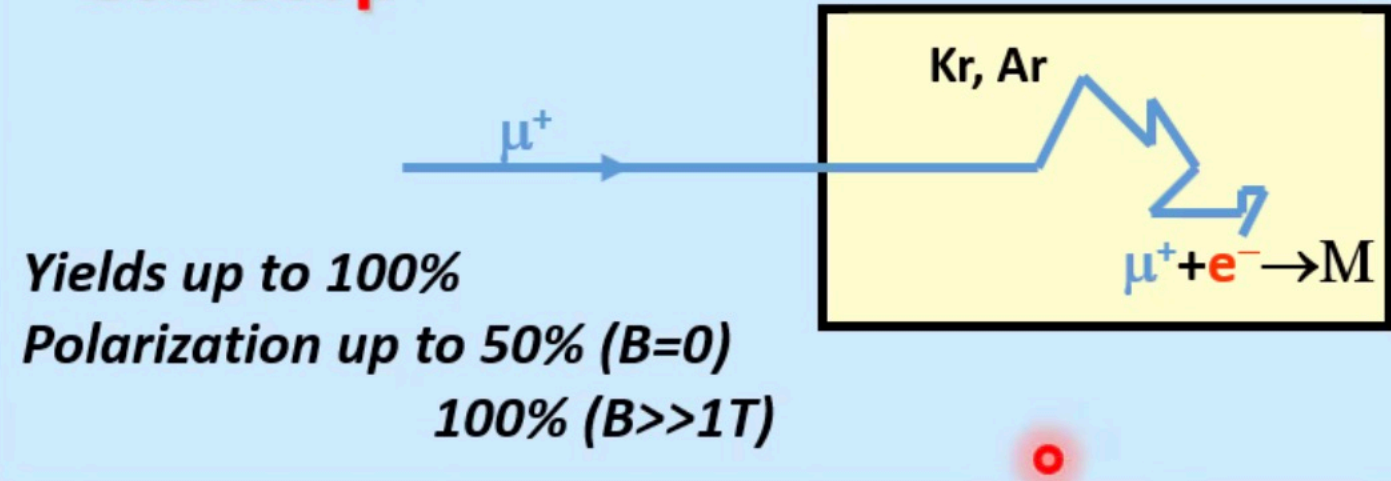

Yields up to 100%  
Polarization up to 50% (B=0)  
100% (B>>1T)

*foreign gas effects*

## • Hot Metal(W)

U line

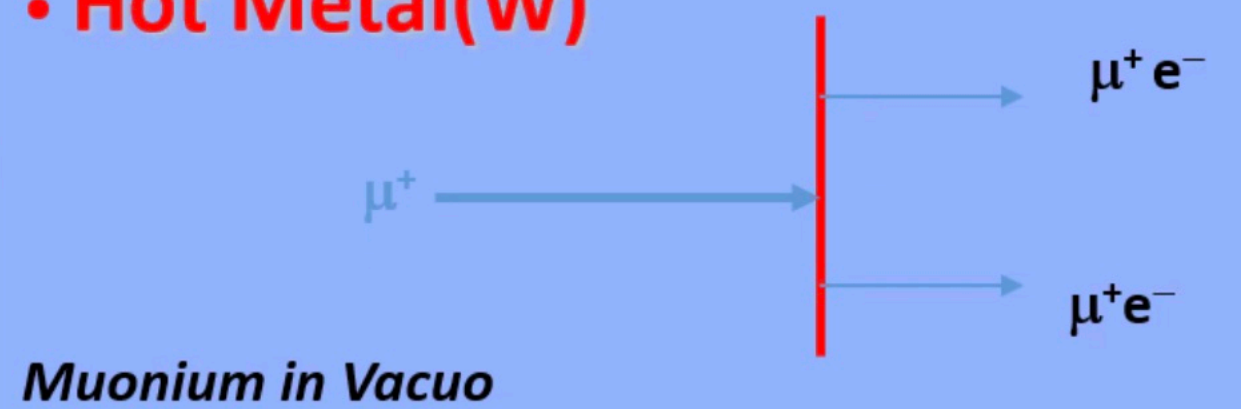

*Muonium in Vacuo*

*thermal energy (2000K)*

## • SiO<sub>2</sub> Aerogel

g-2/EDM  
Mu 1s-2s



*Thermal Muonium in Vacuo*  
Yields up to < 1 %  
Polarization 30(10)%

*velocity 1.5 cm/τ<sub>μ</sub>*  
*less fragile targets*

# Muonium in Vacuo from SiO<sub>2</sub> AEROGELS

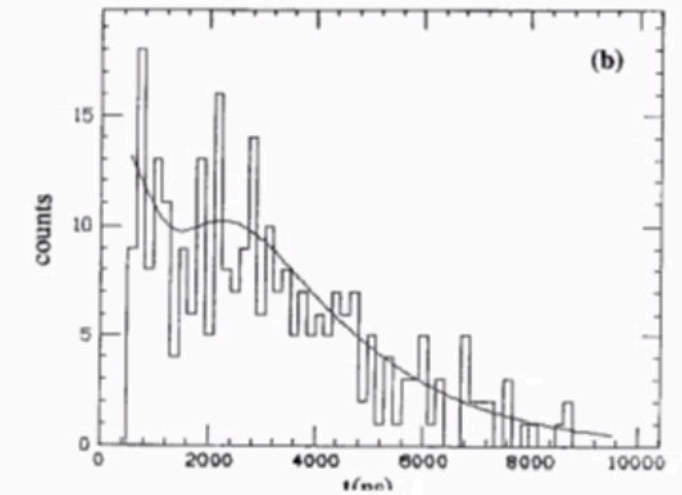
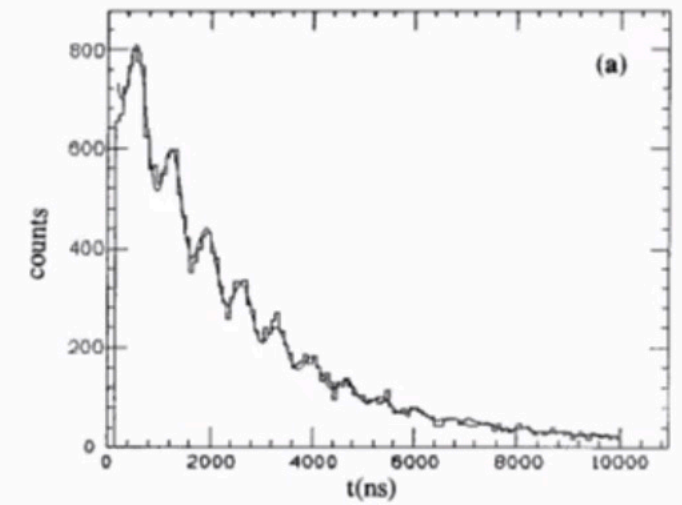
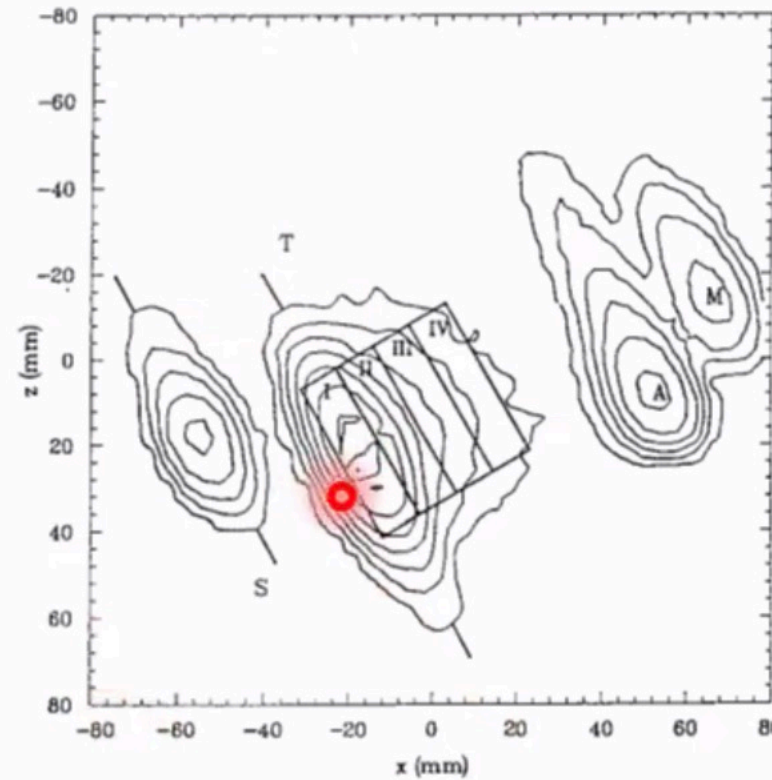
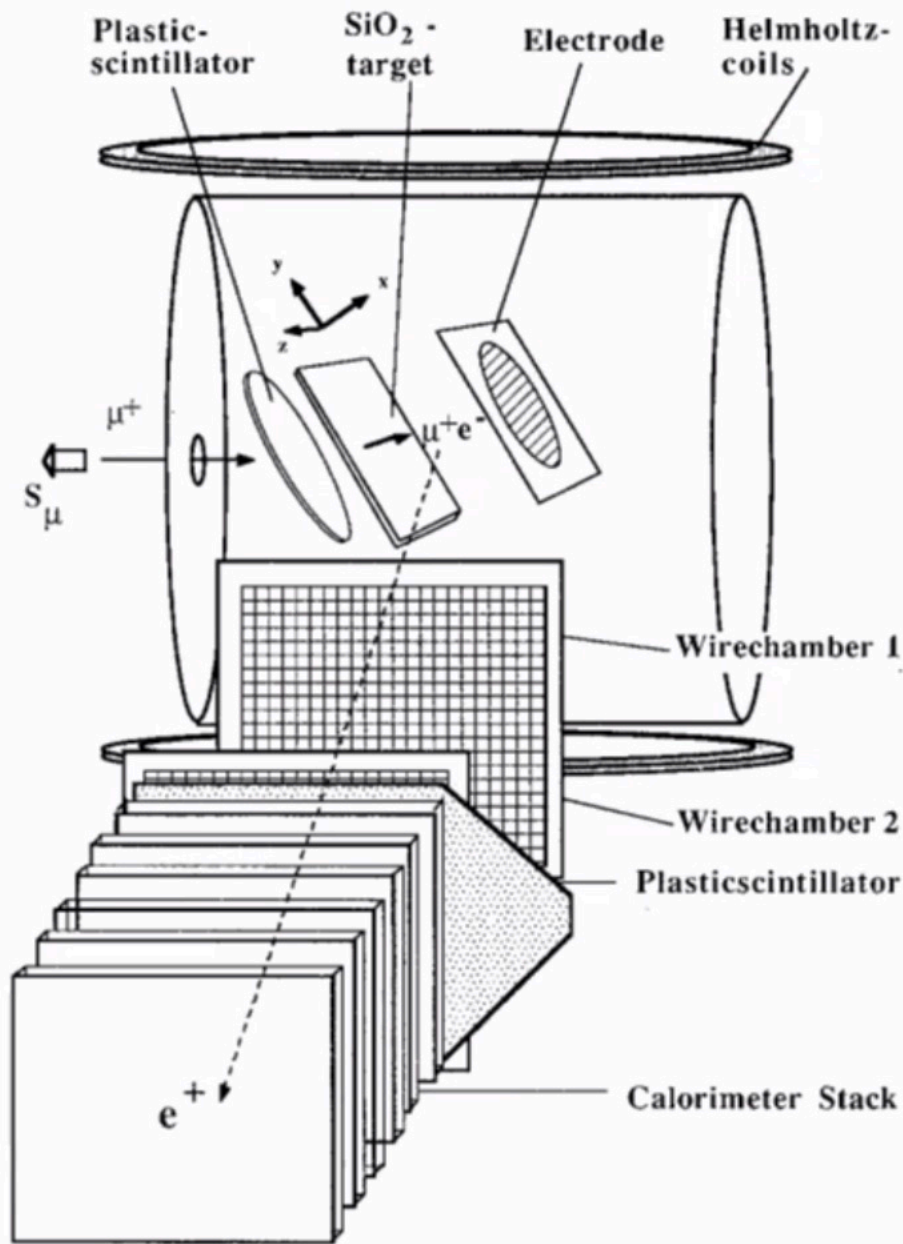

W. Schwarz, V. Ebert, H. Geerds, K. Jungmann, S. Kirches, S. Koppe, F. Maas, H.-J. Munding 1, G. zu Putlitz, J. Rosenkranz 2, W. Schiffer 3, G. Schiff and Z. Zhang  
 Journal of Non-Crystalline Solids 145 (1992) 244

Target	Surface	Thickness (mg/cm <sup>2</sup> )	μ <sup>+</sup> beam momentum, p (MeV/c)	Δp/p (%)	M/μ <sub>stop</sub> (%)
powder M5	fluffy	7.5	19.5 (RAL)	5	8.2(1.0)
	compressed	7.8	18.5 (PSI)	3	2.5(5)
aerogel No. 3	untreated	42	26.5 (PSI)	3	1.0(2)
	ethanol treated	42	26.5 (PSI)	3	1.5(2)
aerogel No. 4	enlarged + ethanol treated	60	26.7 (RAL)	5	2.3(3)

from K. Jungmann's talk in "New Developments of Muon Precision Physics"

# Muonium in Vacuo from SiO<sub>2</sub> AEROGELS

Diplomarbeit (Master Thesis)  
 M. Springer  
 University of Heidelberg (1993)

- Yield depends on
- structure of aerogel
  - treatment of surface
  - history of aerogel
  - $\mu^+$  beam  $\Delta p/p$
  - Similar to SiO<sub>2</sub> powder after grinding of aerogel to powder
  - Aging not studied, yet
- (measurements in old  $\mu E4$  area of PSI)

Tgt Nr.	Eigenschaften	$p$ [ $\frac{MeV}{c}$ ]	$d_F$ [ $\frac{mg}{cm^2}$ ]	$\rho$ [ $\frac{mg}{cm^3}$ ]	$F$ [ $cm^2$ ]	$C_{Mstop}$ $\frac{M}{\mu_{stop}}$ [%]	$C_{Mfree}$ $\frac{M}{\mu_{free}}$ [%]
#1	Aluminiumfolie Dicke $\approx 20\mu m$	n.a.	5.4	$\approx 2700$	154	0	0
#2	SiO <sub>2</sub> - Pulver	23	9	32	154	$8.27 \pm 0.31$	$4.60 \pm 0.20$
#3	Aerogel, längere Zeit der Luft ausgesetzt	24	7.5	5	40	$2.32 \pm 0.13$	$1.74 \pm 0.11$
#4	Aerogel, neu	24.5	12.8	16	10	$0.99 \pm 0.12$	$0.28 \pm 0.02$
#5	Aerogel, neu	26	27.5	55	16	$0.67 \pm 0.12$	$0.68 \pm 0.12$
#5a	Aerogel, Oberfläche aufgeraut	26	27.5	55	16	$0.68 \pm 0.08$	$0.60 \pm 0.09$
#6	Aerogel, 1.5min Mikrowelle	26	27.5	55	16	$0.63 \pm 0.03$	$0.40 \pm 0.02$
#7	Aerogel, 6min Mikrowelle	26	27.5	55	16	$0.24 \pm 0.08$	$0.11 \pm 0.03$
#8	Aerogel, mit Alkohol behandelt	24	27.5	55	16	$0.71 \pm 0.15$	$0.53 \pm 0.10$
#9	Aerogel, neu	24	9	18	19.6	$1.57 \pm 0.20$	$0.76 \pm 0.08$
#10	Aerogel, alt	24	12.8	4	3.1	$0.80 \pm 0.46$	$0.38 \pm 0.22$
#11	Aerogel, alt	27	56	160	12	$1.12 \pm 0.13$	$1.20 \pm 0.14$
#12	Fullerene (C <sub>60</sub> ) Dicke $\approx 1.5mm$	28	$\approx 210$	$\approx 1400$	12	$1.85 \pm 0.23$	$0.55 \pm 0.07$
#13	Watte	24	3.6	10	154	$2.25 \pm 0.46$	$0.70 \pm 0.14$
#14	SiO <sub>2</sub> - Pulver auf Watte	25	5.8	17	154	$11.43 \pm 0.31$	$1.86 \pm 0.19$
#15	MCP, unbehandelt Dicke $\approx 2mm$	28	$\approx 400$	$\approx 2000$	20	$2.44 \pm 0.34$	$1.11 \pm 0.11$
#16	MCP, Kanäle mit SiO <sub>2</sub> - Pulver gefüllt	28	$\approx 400$	$\approx 2000$	20	$1.99 \pm 0.23$	$0.81 \pm 0.10$
#17	Tgt #4 und #9 zerrieben auf Watte	24	7.1	20	154	$3.59 \pm 0.26$	$1.68 \pm 0.13$

Muon Science Establishment

# Muonium in Vacuo from SiO<sub>2</sub> GELS

Tgt Nr.	Eigenschaften	$p$ [ $\frac{MeV}{c}$ ]	$d_F$ [ $\frac{mg}{cm^2}$ ]	$\rho$ [ $\frac{mg}{cm^3}$ ]	$F$ [ $cm^2$ ]	$C_{Mstop}$ $\frac{M}{\mu_{stop}}$ [%]	$C_{Mfree}$ $\frac{M}{\mu_{free}}$ [%]
#1	Aluminiumfolie Dicke $\approx 20\mu m$	n.a.	5.4	$\approx 2700$	154	0	0
#2	SiO <sub>2</sub> - Pulver	23	9	32	154	8.27 ± 0.31	4.60 ± 0.20
#3	Aerogel, längere Zeit der Luft ausgesetzt	24	7.5	5	40	2.32 ± 0.13	1.74 ± 0.11
#4	Aerogel, neu	24.5	12.8	16	10	0.99 ± 0.12	0.67 ± 0.12
#5	Aerogel, neu	26	27.5	55	16	0.67 ± 0.12	0.67 ± 0.12
#5a	Aerogel, Oberfläche aufgeraut	26	27.5	55	16	0.67 ± 0.12	0.67 ± 0.12
#6	Aerogel, 1.5min Mikrowelle	26	27.5	55			
#7	Aerogel, 6min Mikrowelle	26	27.5	55			
#8	Aerogel, mit Alkohol behandelt	24					
#9	Aerogel, neu						

Target	Surface	Thermal muonium yield $M / \mu_{stop}$	Thickness (mg/cm <sup>2</sup> )	$\mu^+$ beam momentum, $p$ (MeV/c)	$\Delta p / p$ (%)	$M / \mu_{stop}$ (%)
#10	Aerogel, al...		7.5	19.5 (RAL)	5	8.2(1.0)
#11	Aerogel, al...		7.8	18.5 (PSI)	3	2.5(5)
#12	Aerogel, al...		42	26.5 (PSI)	3	1.0(2)
#13	Aerogel, al...		42	26.5 (PSI)	3	1.5(2)
#14	powder M5		60	26.7 (RAL)	5	2.3(3)
#15	aerogel No. 3	fluffy				
#16	aerogel No. 4	compressed				
#17	Aerogel target No. 4 is supplied by M.J. van Bommel (density 160 mg/cm <sup>3</sup> )	untreated				
#18		ethanol treated				
#19		enlarged + ethanol treated				
#20			$\approx 400$	$\approx 2000$	20	2.44 ± 0.34
#21			$\approx 400$	$\approx 2000$	20	1.99 ± 0.23
#22			24	7.1	20	3.59 ± 0.26

from K. Jungmann's talk in "New Developments of Muon Precision Physics"

Similar to SiO<sub>2</sub> powder after grinding of aerogel to powder

Aging not studied, yet (measurements in old  $\mu E4$  area of PSI)



# Muonium from Drilled Aerogels

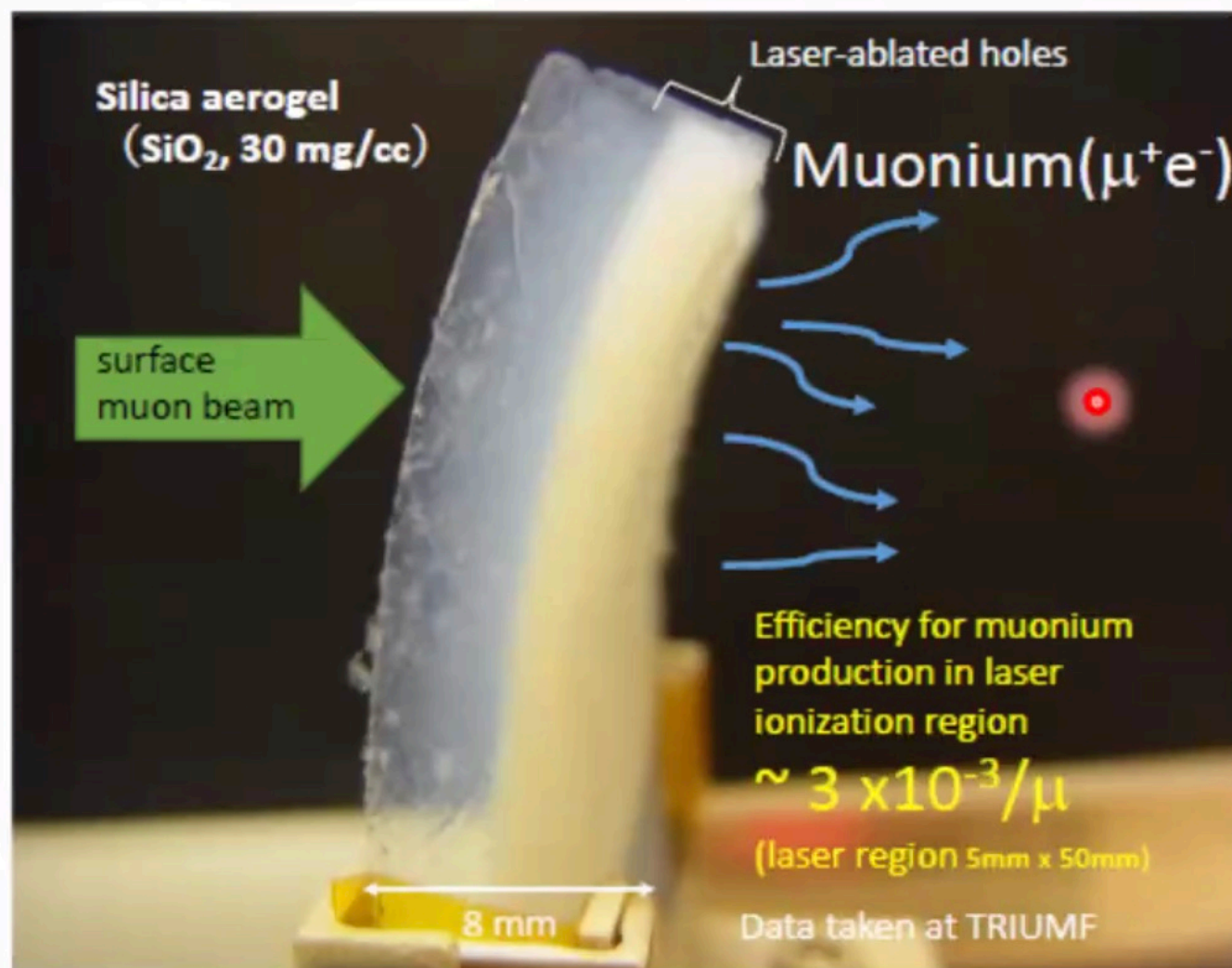
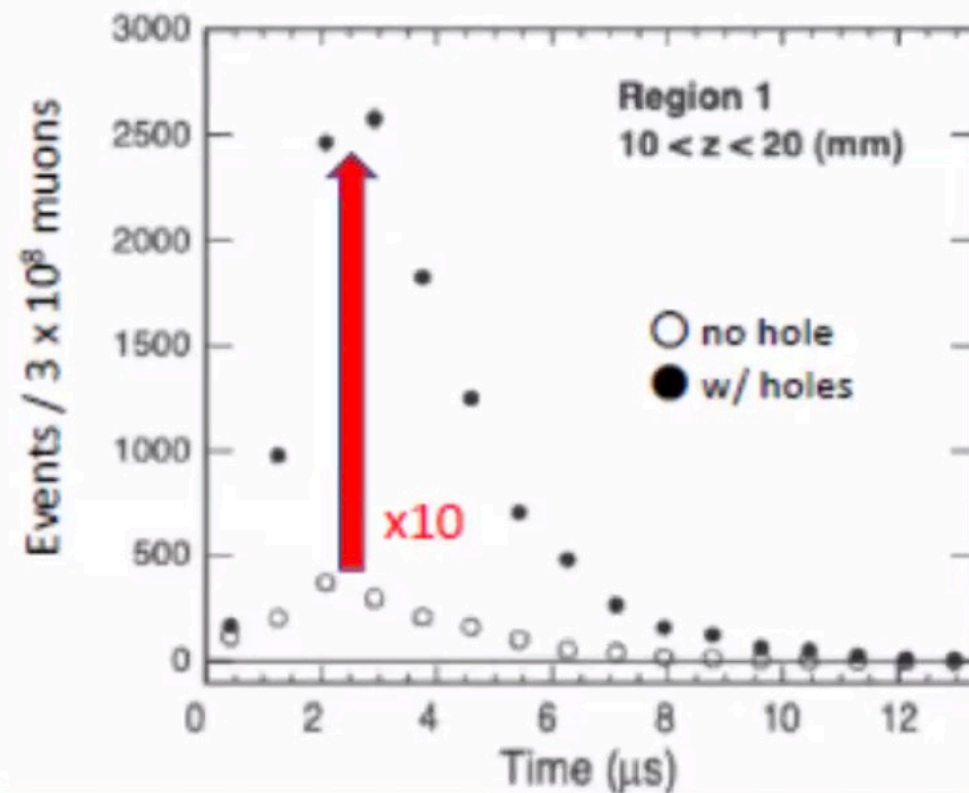
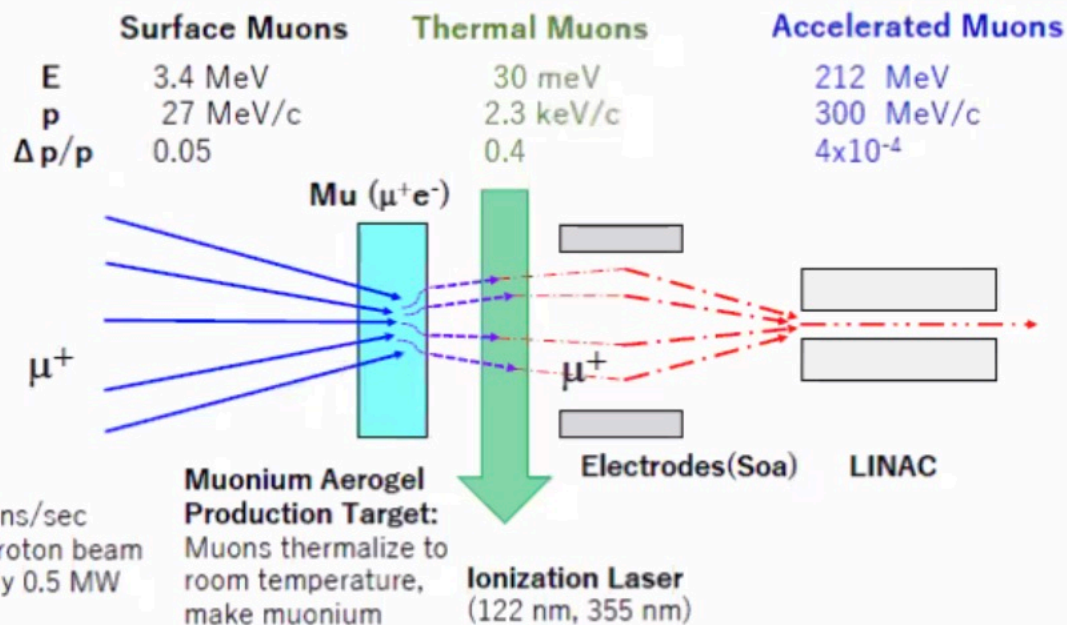

Sample	Laser-ablated structure (pitch)	Vacuum yield (per $10^3$ muon stops)
Flat	none	$3.72 \pm 0.11$
Flat (Ref. [7])	none	$2.74 \pm 0.11$
Laser ablated	500 $\mu$ m	$16.0 \pm 0.2$
Laser ablated	400 $\mu$ m	$20.9 \pm 0.7$
Laser ablated	300 $\mu$ m	$30.5 \pm 0.3$

slides compiled from  
 J-PARC Muon g-2/EDM and Muonium, D. Kawai  
 Muon g-2 Elba Physics Week, May 27-June 1, 2019

- curious to learn about long term stability
- $\text{SiO}_2$  powder targets known to degrade within one week

# Target and Tracker Install

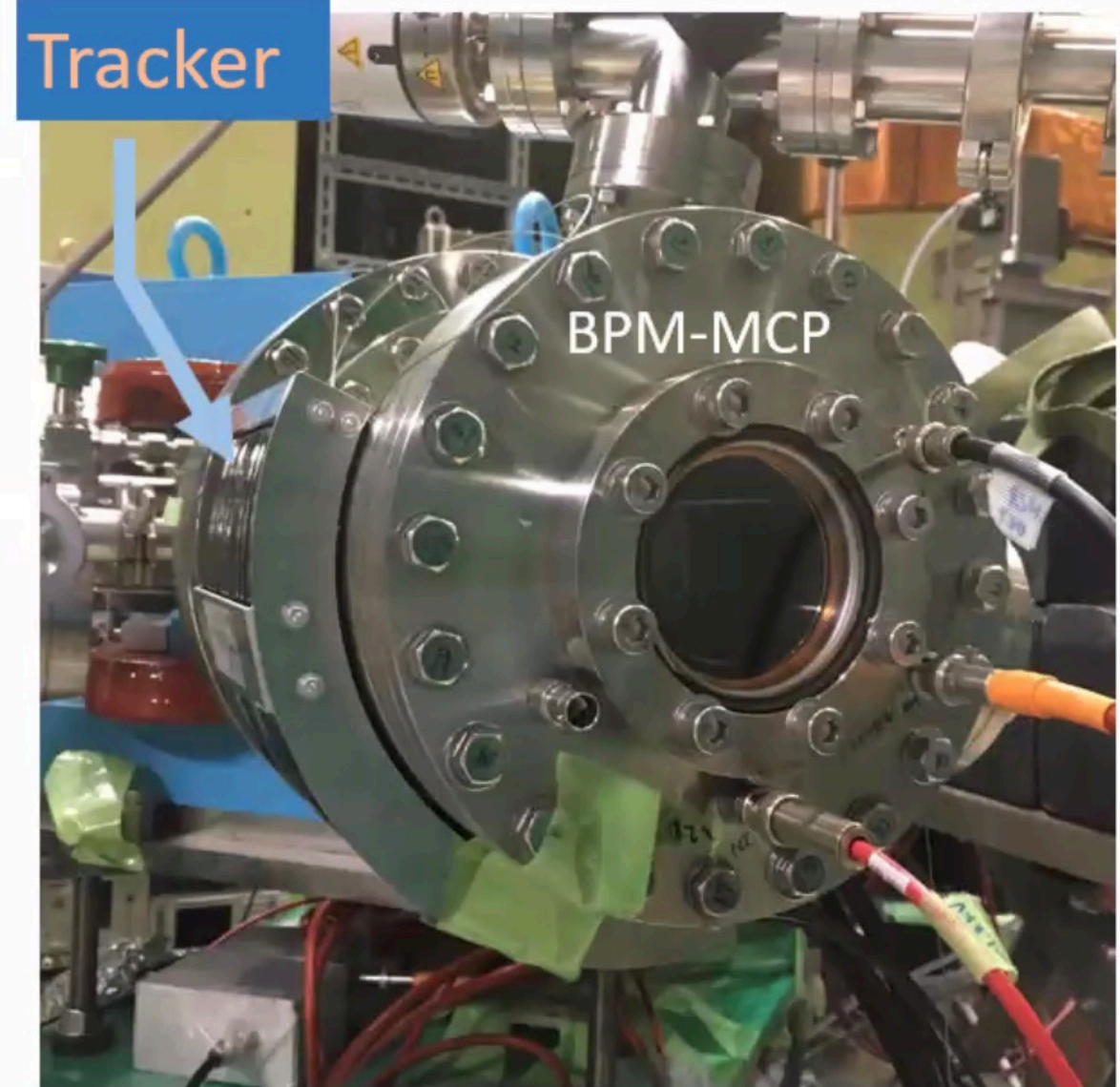
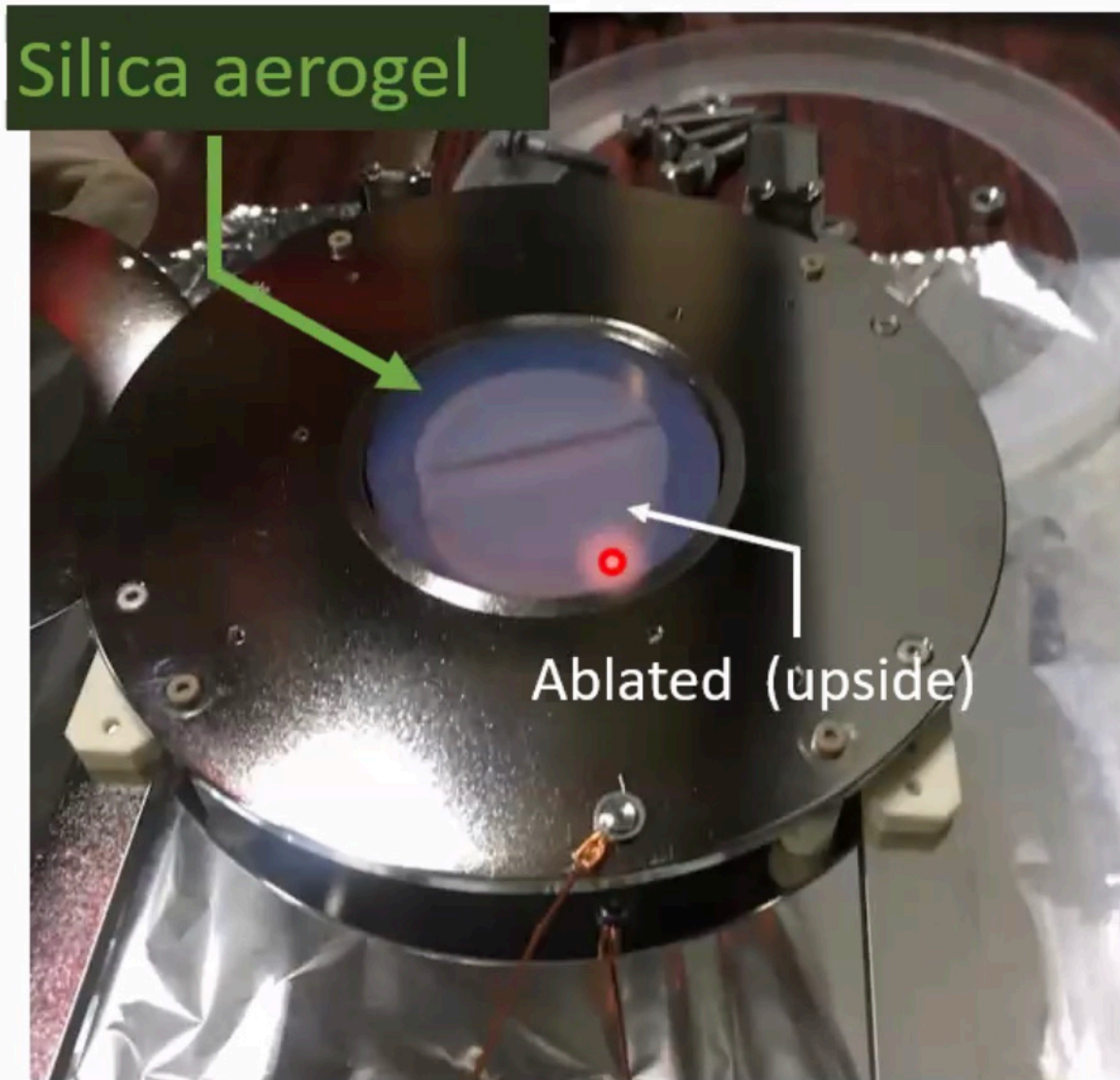

PS telescopes can not distinguish the positron from the target region. To solve this problem, we developed the tracker to identify the electron signal from MCP.

# Ultra-Cold Positive Muon Beams by Laser Ionization of Muonium

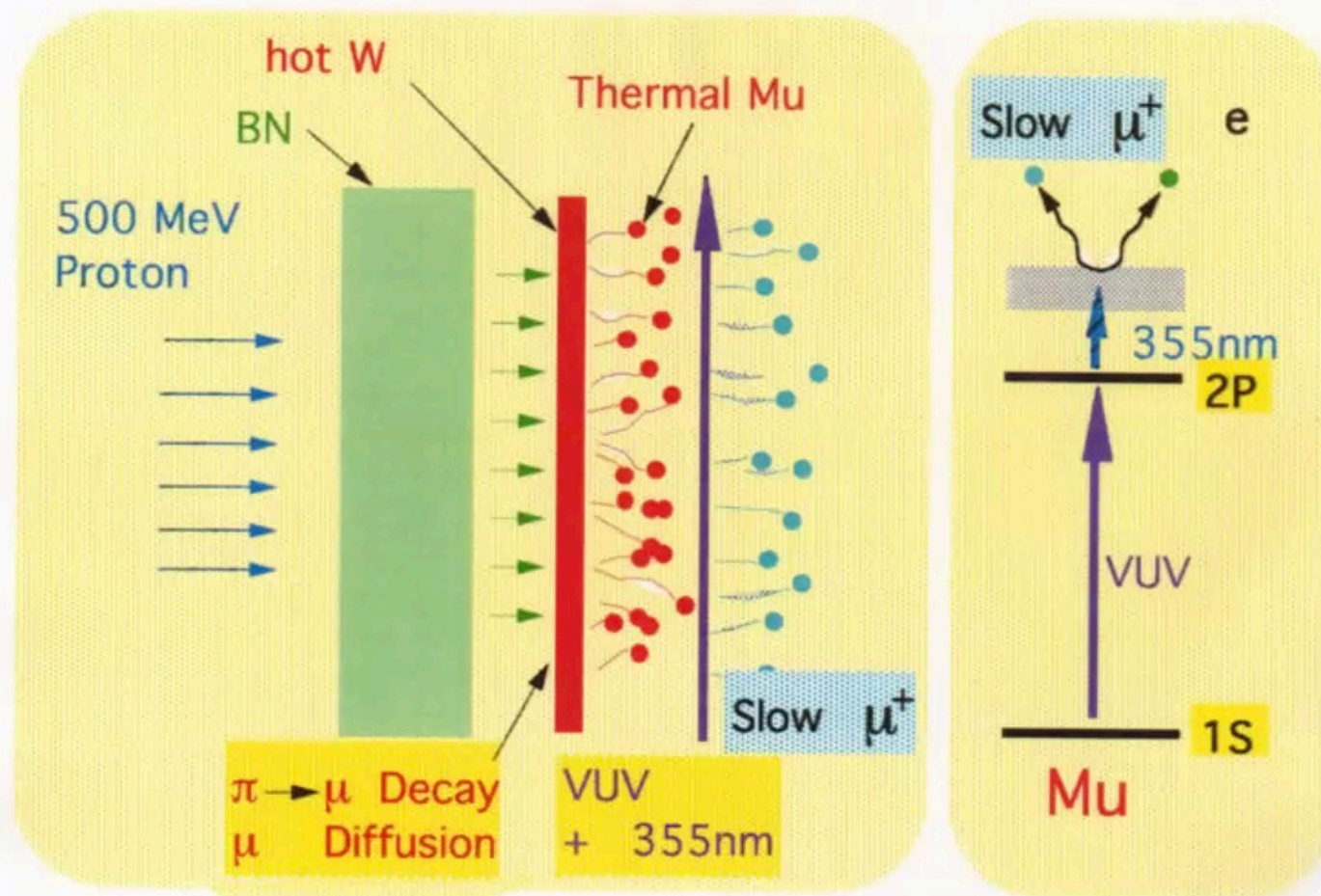

⇒ K. Nagamine and colleagues have been pioneering Ultra-Cold  $\mu^+$  beams, see e.g. K. Nagamine Z. Phys. C56, 215 (1992)

⇒ Constant progress ever since

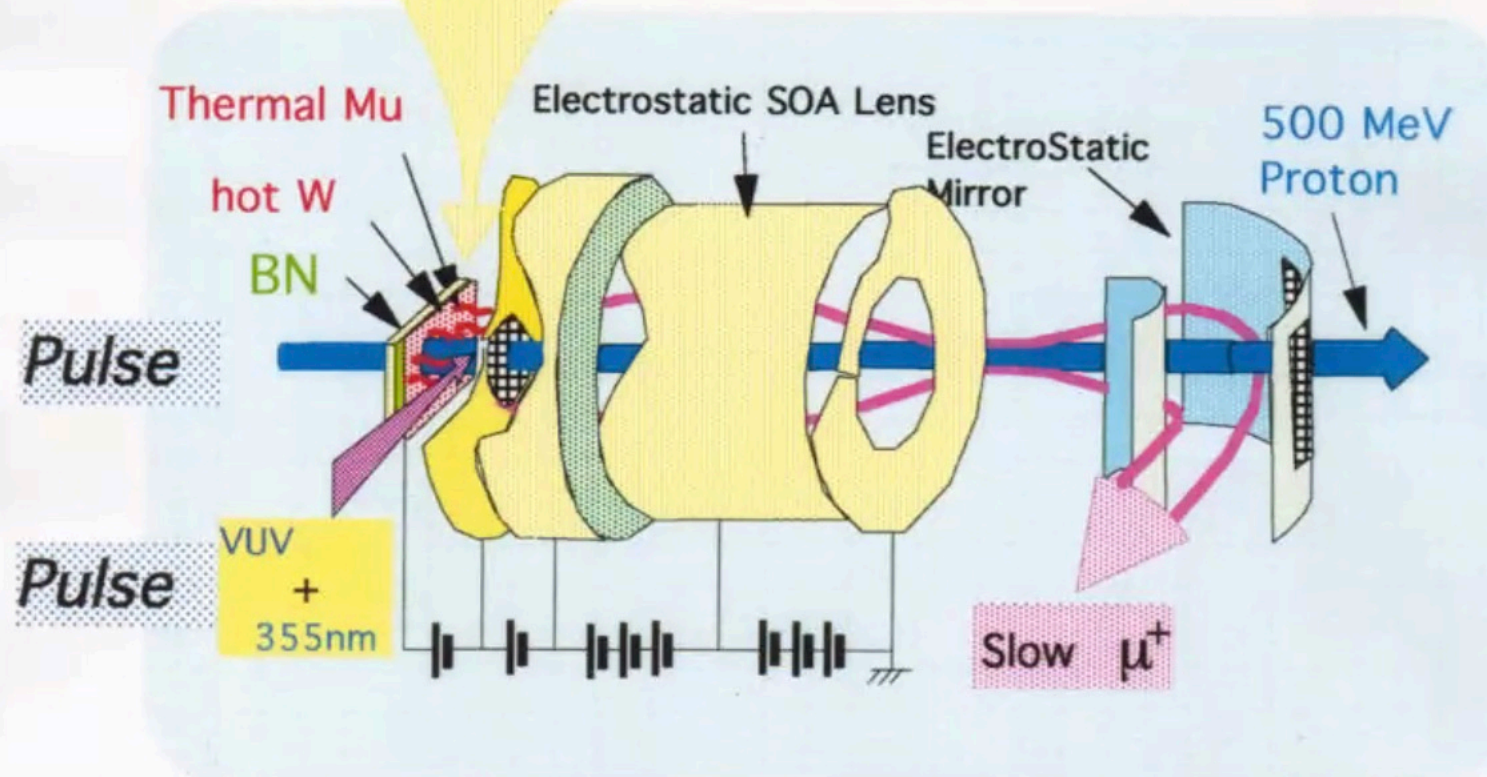

# U-line Laser

## Progress and updates in 2021

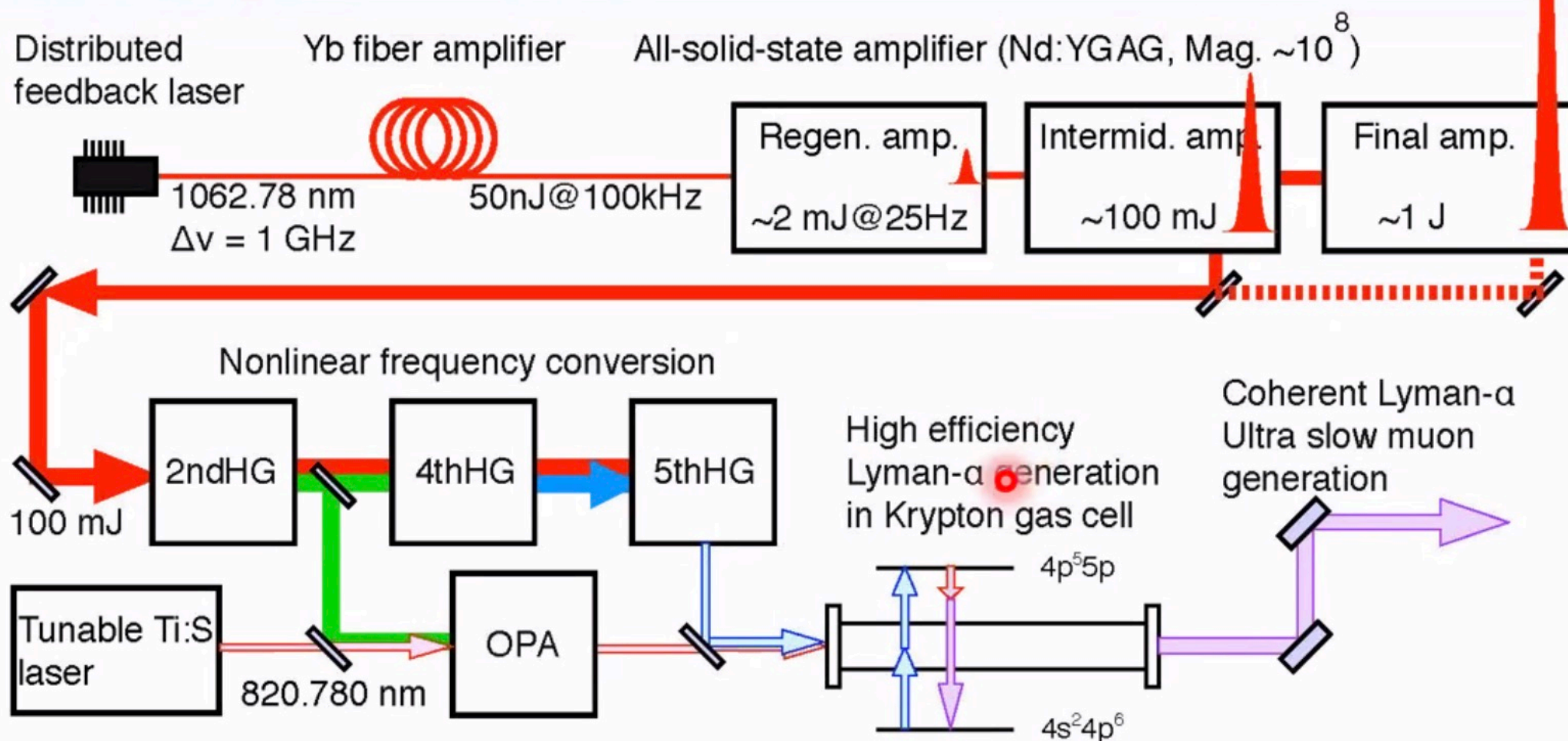

Establishment of a multi-institutional collaboration for laser development

- A new team to collaborate on the ionization laser improvements

Improvements for higher pulse energy of Lyman- $\alpha$

- Phase compensation in the laser gain medium using a deformable mirror
- Preparation for a new pumping scheme using Nd:YAG ceramic

Improvements for stable and efficient operation of the system

- Automatic, remote alignment of the laser beams
- Remote control of the steering mirrors for Lyman- $\alpha$  to extend the lifetime of element

# U-line Laser

## Progress and updates in 2021

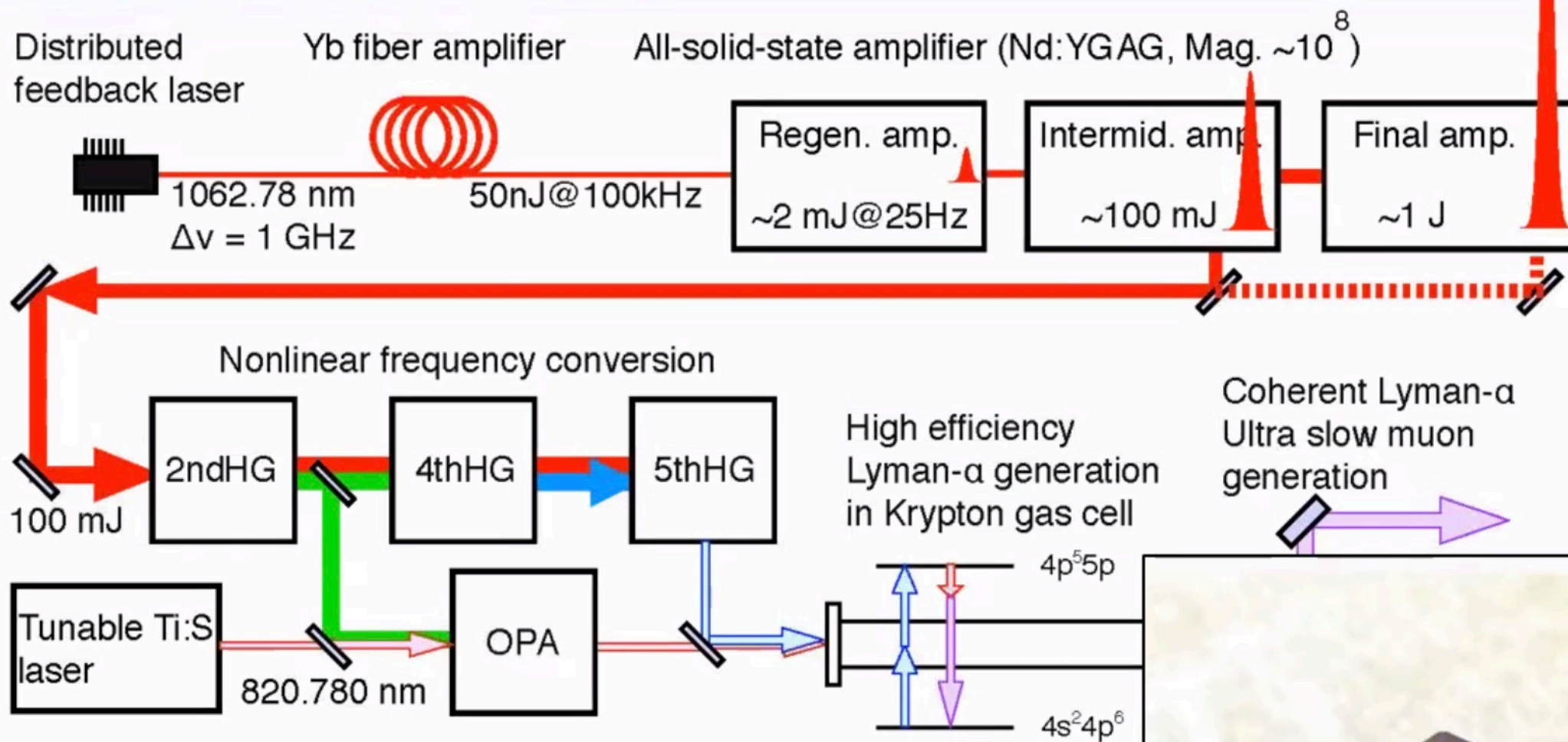

Establishment of a multi-institutional collaboration for laser

- A new team to collaborate on the ionization laser improve

Improvements for higher pulse energy of Lyman- $\alpha$

- Phase compensation in the laser gain medium using a defo

- Preparation for a new pumping scheme using Nd:YSAG ce

Improvements for stable and efficient operation of the system

- Automatic, remote alignment of the laser beams

- Remote control of the steering mirrors for Lyman- $\alpha$  to exte

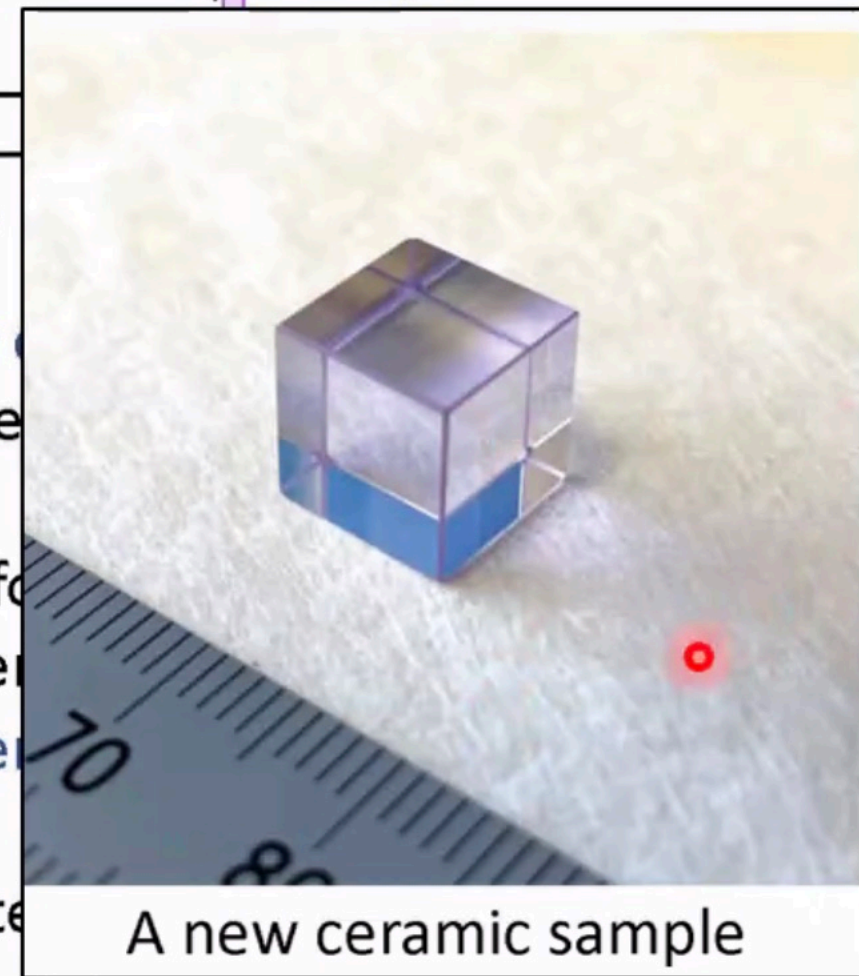

# U-line Laser

## Development of an alternative ionization scheme through collaboration

- The original scheme: Highly efficient but challenging  
1s-2p (VUV one-photon excitation)

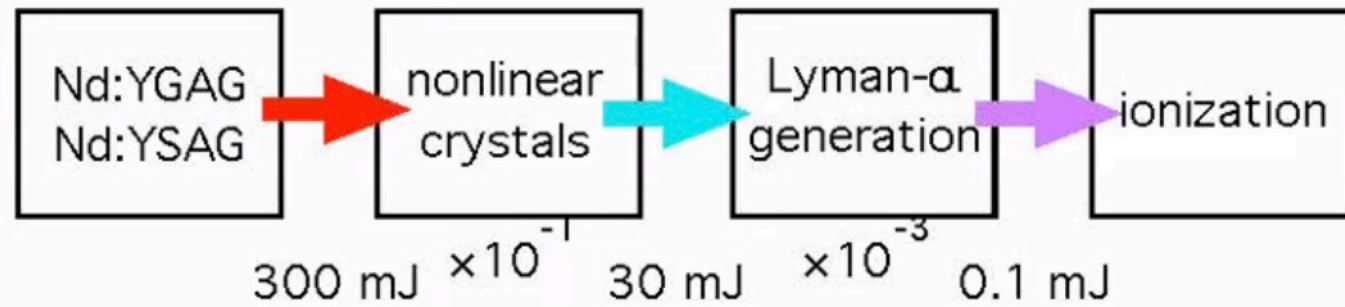

- An alternative scheme: Well established with medium eff.  
1s-2s (UV two-photon excitation)

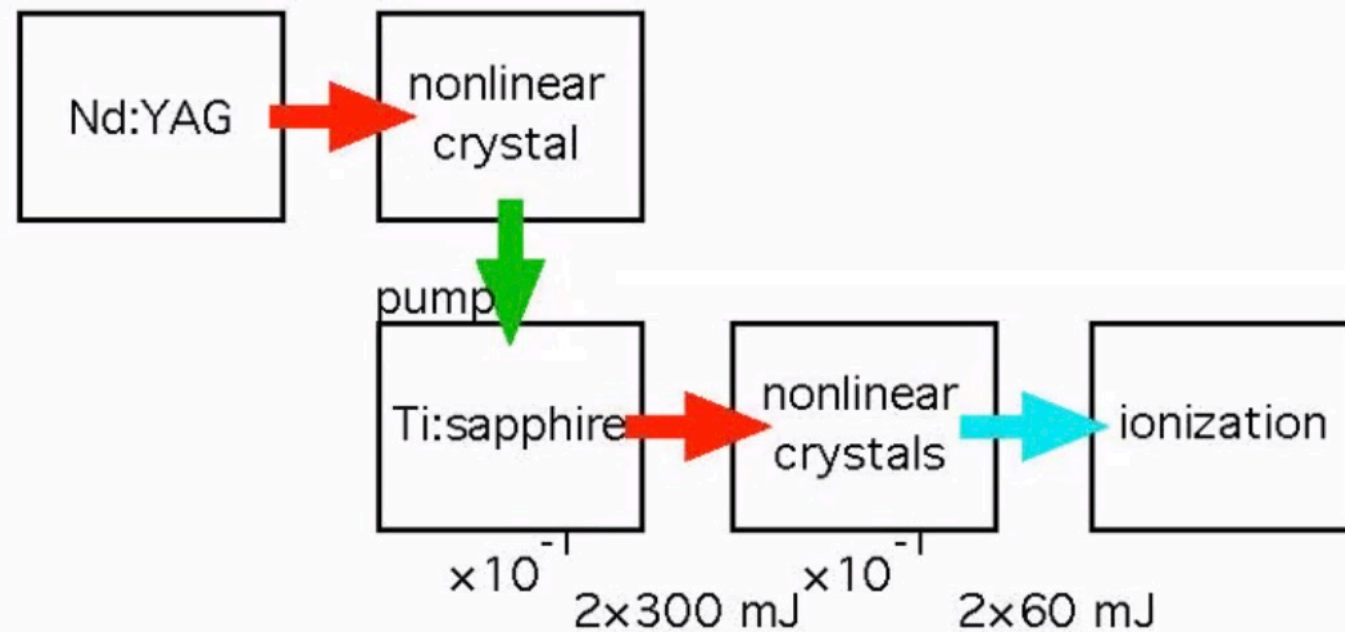

- The alternative system has been developed by the group of Okayama Univ. and to be tested in muonium 1S-2S spectroscopy at MLF MUSE S2.

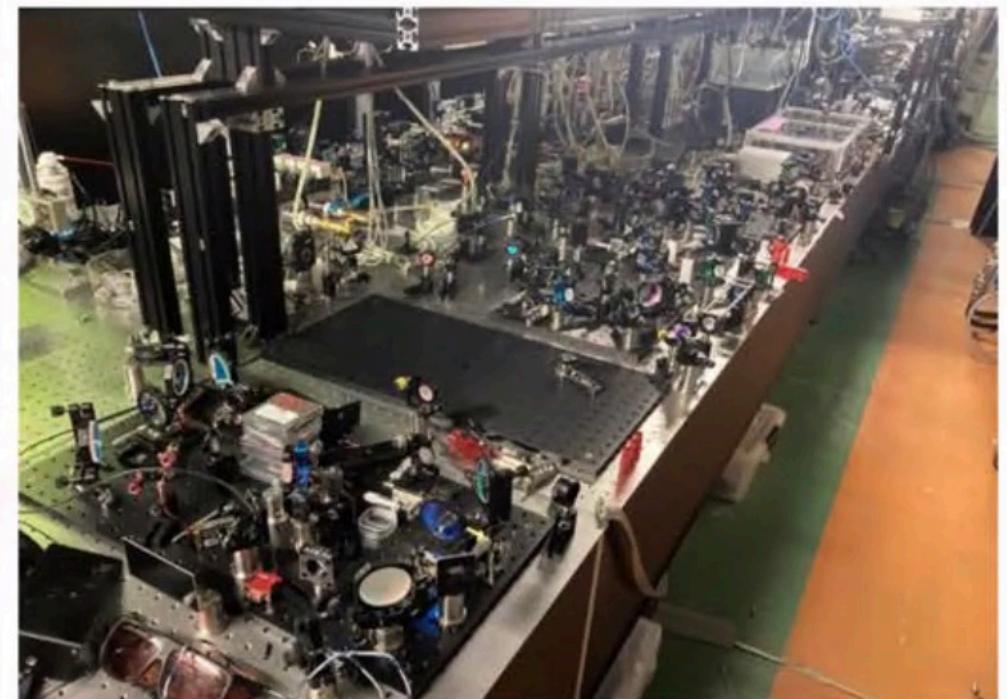
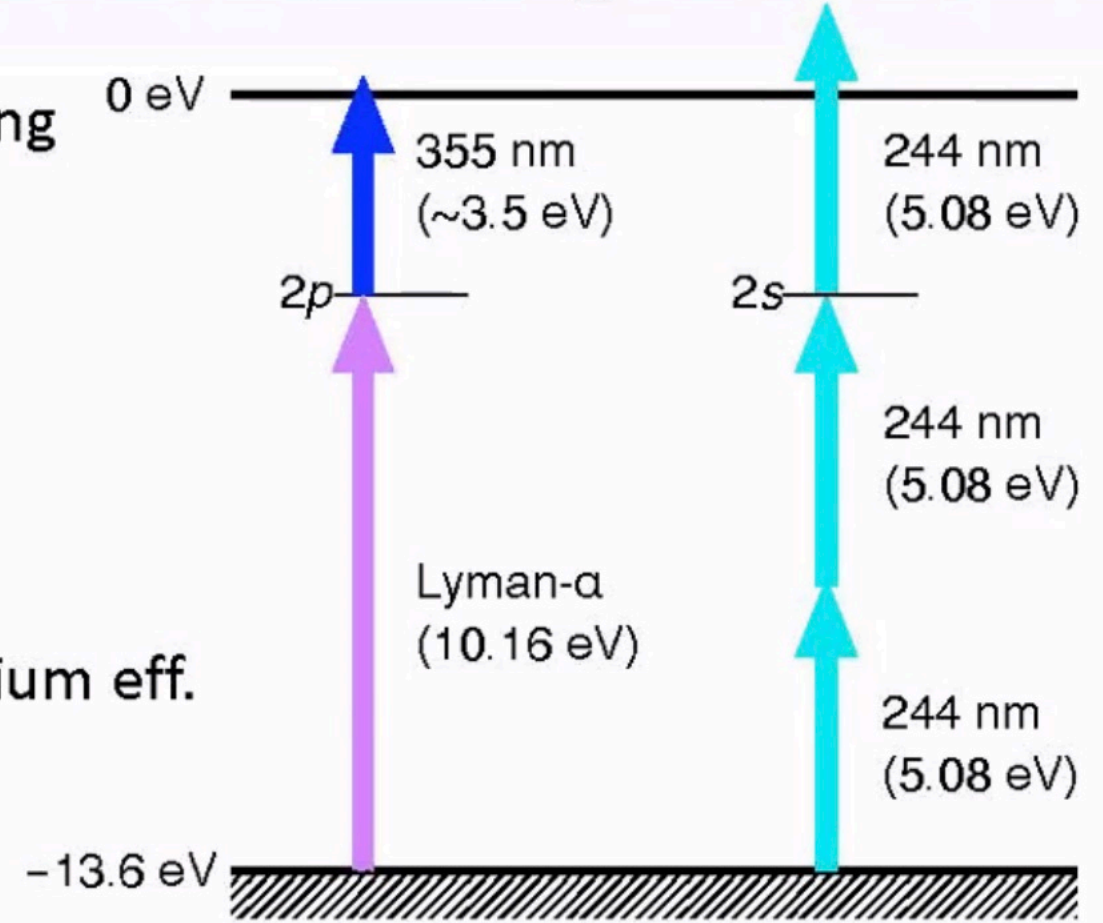

# Summary

- Mu- $\overline{\text{Mu}}$  conversion search is a global trend (PSI, CSNS)
- Possibility of the low BG measurement was demonstrated in the feasibility study in the D line.
- We can reach the sensitivity of the preceding study at PSI,  $O(10^{-11})$ , by 1-year data acquisition.
  - Surface muon:  $10^7$  /s (in the S line)
  - Mu/ $\overline{\text{Mu}}$  ionization: 0.2% (laser: under development)
  - Transmission eff. through the slow optics: 10%
  - Detection efficiency: 20% (under development)
- Next (Next) prospect
  - Surface muon:  $10^8$  /s (in the H line)
  - Realization of cold Mu target and multi-path laser:  $\times 10$

# Current situation

- The cost of developing the detector and so on is granted in KAKENHI-B from this FY.
- Some other parts are also granted.
- GAKUSHIN PD is joined. He is working hard to maximize the detection efficiency.
- You are always welcome! Let's reveal new physics!

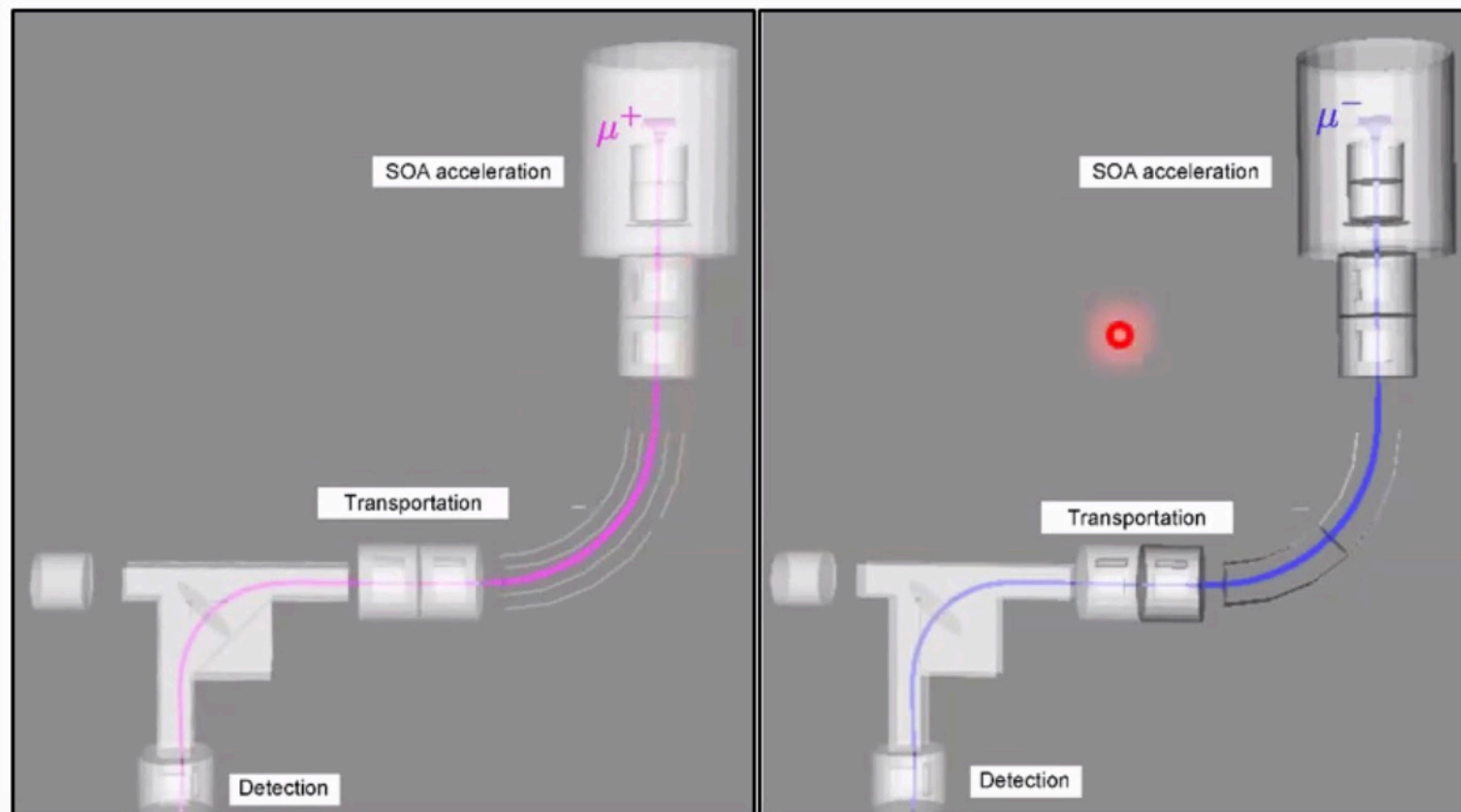



# New physics to Mu-antiMu conv.

13/27

## Classification of new particles & interactions to generate Mu-to- $\bar{\mu}$ transition

1.  $\Delta L_e = \Delta L_\mu = 0$

- mass term of SM singlet which violates lepton number
- loop
- e.g. Majorana  $\nu$  mass

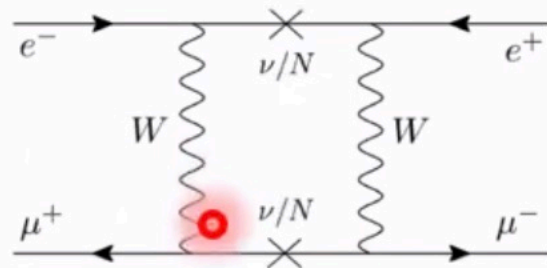

2.  $(\Delta L_e, \Delta L_\mu) = (\pm 2, 0), (0, \pm 2)$

- doubly-charged mediator
- tree
- LNV is not needed.
- If mediator couples to  $W^+W^+$ ,  $0\nu 2\beta$  is induced.

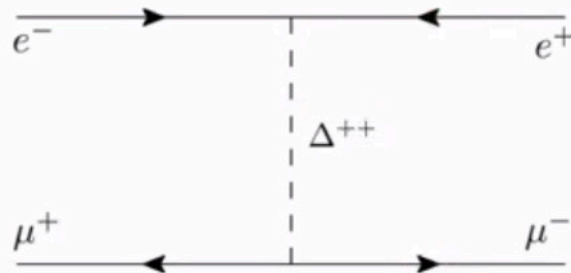

14/27

3.  $\Delta L_e = -\Delta L_\mu = \pm 1$

- neutral mediator
- tree
- LNV is not needed.

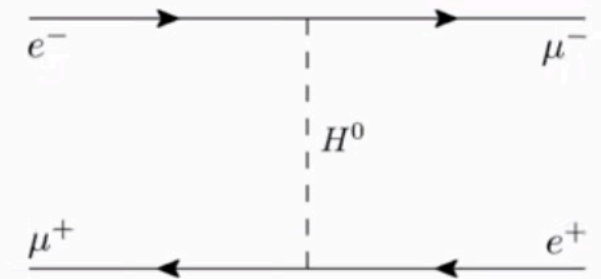

4.  $(\Delta L_e, \Delta L_\mu) = (\pm 1, 0), (0, \pm 1)$

- loop
- model-independently, strongly constrained by  $\mu \rightarrow e\gamma$  or  $\mu \rightarrow 3e$

